

UNITED STATES
DEPARTMENT OF AGRICULTURE
SOIL CONSERVATION SERVICE

P. O. Box 713
Lincoln 1, Nebraska

September 25, 1951

Mr. Hans L. Bille
Assistant State Engineer
State of Montana
P. O. Box 873
Billings, Montana

Dear Mr. Bille:

In accordance with your recent request, I am glad to send you a copy of our Survey Report relating to irrigation problems, Hysham Bench Project, Treasure County, Montana.

As you probably know, the plan was accepted by the Irrigation District and construction work was completed last year.

There is no charge for the report.

Very truly yours,

C. J. Francis,
Regional Engineer

Encl. (1)

U. S. Department of Agriculture
Soil Conservation Service H. H. Bennett, Chief
Great Plains Region
A. E. McClymonds Regional Conservator

SURVEY REPORT
ON
IRRIGATION PROBLEMS
HYSHAM BENCH PROJECT
IN
TREASURE COUNTY, MONTANA

Prepared at the
Request of the Supervisors
of the
Treasure County Soil Conservation District

Region 5
Lincoln, Nebraska
October, 1949

MEMORANDUM

TO: A. E. McClymonds, Regional Conservator

FROM: K. M. Sandals, Chief, Regional Water Conservation Division
and C. J. Francis, Chief, Regional Engineering Division.

We are submitting to you for review and transmittal to the Supervisors of the Treasure County Soil Conservation District this report entitled "Survey Report on the Hysham Bench Project, Treasure County, Montana." Investigations leading to the preparation of this material were undertaken at the request of the Supervisors of the District.

A preliminary examination was made of this project and a report of that examination prepared by W. F. Long, Soil Conservationist (Engineer), a member of the Regional Water Conservation Division, under the supervision and with the assistance of Mr. John S. James, Irrigation Engineer, Division of Irrigation (Research).

Field surveys and studies were made and the plan of distribution and disposal works prepared by personnel of the Regional Engineering Division. Mr. Roy L. Fox was in direct charge of the work, under the supervision of Mr. Merritt E. Hoffman and under the general direction and supervision of Mr. Dwight S. McVicker, Regional Construction Engineer. Mr. John S. James, Irrigation Engineer (Research), assisted and consulted in the work and in the preparation of this report.

Local Service personnel cooperated and assisted: The Work Unit also provided office facilities for field work.

The Montana State Water Conservation Board cooperated in the work particularly through supplying engineering data and providing consultation with its engineers.

One could hardly over-emphasize the importance of the job which is the subject of this report. Its broad public value is evident as a part of the conservation program of the Treasure County Soil Conservation District which is, in turn, part of State and Federal programs for conserving and using rightly our water-land resources. This job is of definite interest to the Public as represented by the Nation and the State. It is vital to the success of the "Project" which has been organized by the local landowners. Success or failure of individual farmers may be determined by whether this job is carried out rightly and promptly or haphazardly over a long period. The Project will succeed and be able to maintain its service only if, or when, the water is available to the lands for production.

The individual farmer will be called upon to bear his part of the cost of maintaining and operating the project works and he can meet this demand only from his financial reserves until such time as he can realize production from the water on his land. The period which must elapse until he can get returns from the water must be as short as possible, for if it is too long, it will exhaust the resources of all but those who have considerable outside income or unusually large financial reserves.

TABLE OF CONTENTS

| | Page |
|-------------------------------------------------------|------|
| FOREWORD - - - - - | A |
| INTRODUCTION - - - - - | 1 |
| Location and Size - - - - - | 1 |
| Background - - - - - | 1 |
| PURPOSE AND SCOPE OF REPORT - - - - - | 3 |
| GENERAL DESCRIPTION OF THE AREA - - - - - | 5 |
| Climate - - - - - | 5 |
| Precipitation - - - - - | 5 |
| Temperatures - - - - - | 6 |
| Soils - - - - - | 6 |
| Topography - - - - - | 7 |
| Special Features - - - - - | 7 |
| Cultural Features - - - - - | 8 |
| Agriculture - - - - - | 8 |
| BASIC DATA AND MATERIAL AVAILABLE - - - - - | 9 |
| THE DISTRIBUTION-SYSTEM PLAN - - - - - | 9 |
| Criteria Used and Assumptions Made - - - - - | 9 |
| Layout of the System - - - - - | 12 |
| Location and Capacities of Orifice Turnouts - - - - - | 12 |
| Lateral Wasteways - - - - - | 12 |
| Map Description and Nomenclature - - - - - | 12 |
| DESCRIPTION OF DISTRIBUTION SYSTEM - - - - - | 13 |
| (Orifice Turnouts No. 1 through No. 19) - - - - - | 13 |
| (Orifice Turnouts No. 31 through No. 75) - - - - - | 19 |
| Summary of Distribution System - - - - - | 32 |
| TABLE I - - - - - | 32 |
| THE WATER DISPOSAL SYSTEM - - - - - | 33 |
| Description of Disposal System - - - - - | 34 |
| PD-1 - - - - - | 34 |
| D-2, D2-1, PD3 - - - - - | 35 |
| RD4, D-5.0 - - - - - | 36 |
| FD5.1, D6.0 - - - - - | 39 |
| D6.1, PD7, FD8 - - - - - | 42 |
| D9.0, D9.1 - - - - - | 43 |
| FD10, FD11, RD12 - - - - - | 44 |
| PD13, FD14, FD15.0 - - - - - | 45 |
| RD15.1 - - - - - | 46 |
| PD15.2, RD16, D17, FD18.0 - - - - - | 47 |
| RD19, D20 - - - - - | 48 |
| Inlets to Lowline Canal - - - - - | 49 |

TABLE OF CONTENTS

| | Page |
|-----------------------------------------------------------------------------------------------|--------|
| SUMMARY OF WATER DISPOSAL SYSTEM - - - - - | 49 |
| DISCUSSION OF ENGINEERING DESIGN - - - - - | 50 |
| Laterals - - - - - | 50 |
| Disposal Channels - - - - - | 51 |
| Structures - - - - - | 52 |
| Drawings (5R-10,000.01 -.07,.15,.19) - - - - - | 53 |
| PRELIMINARY COST ESTIMATE - - - - - | 63 |
| AREAS TO BE SERVED - - - - - | 64 |
| TABLE II - Estimated Acreages Served in Each Ownership - Sheet 1 - 5 - - - - - | 64 |
| TABLE III - Estimated Acreages Served from Each Main Canal Turnout - Sheet 1 - 5 - - - - - | 68 |
| GENERAL CONSIDERATIONS - - - - - | 73 |
| RECOMMENDATIONS - - - - - | 74 |
| MAPS 1 and 2 - - - - - | Pocket |
| PLAN-PROFILE - - - - - | Pocket |

F O R E W O R D

A basic principle of the soil conservation program is to recognize the capabilities of each acre of land and to use that acre in accordance with these capabilities. Land, as a productive resource, is a complex of soil, water and other factors. Irrigation supplies any deficiency of water and, with water disposal, makes possible virtual control of one of the two essential factors in productive land. Thus, irrigation makes it possible to develop the full capabilities of the soil.

In a semi-arid climate, where the capabilities of good soil can be realized but fractionally with natural moisture, the public value of making that basic resource fully available is, literally, immeasurable. A relatively small part of the total value of irrigation development is realized by the landowner: This part can be measured although somewhat uncertainly. One rough measure is in increased market value of land; for example, this increase may be from \$20 or \$30 to \$100 or \$150 per acre.

Whatever this margin may be, by this or any other measure, it is earned by the landowner only by investment of time, money and hard work. In this investment "time is of the essence." "Fixed costs" such as interest and project operation costs pile up while the land is being brought into adequate production to meet them. Success or failure of an irrigation enterprise may be determined by the length of the "period of development" as much as by the "cost of water."

An irrigation project to serve a number of landowners and farm units, such as the one discussed in the following report, is necessarily a group enterprise. The water users are inter-dependent to a great extent, whether or not there be any "joint liability" for repayment of construction costs. To a considerable degree, the success of one depends on the success of all.

In the establishment of an irrigation project as a "going concern", as an asset to the public and to the individual farm operators, four steps in development must be accomplished:

Project works must be constructed to make the water supply available to the project area: A distribution system must be provided to make water available from the project system to each tract or farm unit: Each farm unit must be developed and brought into production. With the accomplishment of these three steps in physical development, a truly mutual organization must be effected for orderly, efficient maintenance and operation of the project. ①

Each of these steps is accomplished through a combination of two factors, technical planning and experience of trial and error. The latter is costly in both time and money. To the extent that the

factor of planning can be effectively applied in each step, the other factor will be reduced and ultimate economy in time and money realized. However, not all contingencies can be foreseen and each step in irrigation development can be perfected only through time and experience. There are many things, such as the stabilization of earth banks and structures, which only time can develop. The fact that there is a limit beyond which the time factor can not be reduced, emphasizes the necessity of cutting this factor as nearly as possible to that limit.

Inasmuch as the Montana State Water Conservation Board has performed the initial step in the development of the Hysham Bench Project, some statement should be made of the basic principles and policies of that Board, as understood by the writers of this report.

The Board was created to effectuate a state-wide program to conserve the public water resources of the state and make them available for beneficial use. This program is distinctly not one of "reclamation" or of land development; albeit recognizing that reclamation through irrigation and involving land development is a most important use of water.

The philosophy back of this program is that the water resources of the state are inalienably public property: And, while the individual may acquire rights to use water, in making such use for irrigation he is performing a public function. Between the definite public ownership of the water in the streams and the private use of that water on the land the lines of ownership, control and responsibility may be more or less blurred. A step in clarifying these lines is to assume that it is a public responsibility and may be a proper function of a public agency to make the water resources reasonably available for private use. Adoption of this assumption is implied, at least, in the Montana Water Conservation Program. Such a viewpoint affirms the public ownership of a vital resource, and recognizes a measure of responsibility inherent in that ownership, while leaving to private initiative and enterprise the actual use of the resource.

For the Hysham Bench Project the State Water Conservation Board has planned and constructed works to make a water supply available to the project; and, that agency will perfect these works as found necessary through time and experience. Planning of conservation-irrigation farm development is provided for in the regular program of the Treasure County Soil Conservation District in cooperation with the Soil Conservation Service. The District has recognized the necessity of group action to accomplish the intermediate step of establishing a system for the distribution and disposal of water and has enlisted the cooperation of the Soil Conservation Service in providing a general plan for such a system. To meet the obligation of the Service to provide such technical assistance to the District, this plan has been prepared.

INTRODUCTION

Location and Size

The Hysham Bench Project is on the south side of Yellowstone River valley in southeastern Montana. It includes about 8,500 acres of land lying east, west and south of the town of Hysham, in Treasure County, Montana. A gravity canal of the Yellowstone Irrigation District serves land along the Yellowstone, north of Hysham, and the "Project" includes lands lying above, and south of, the "Yellowstone" Canal.

Irrigation water will be supplied to these lands by two canals constructed by the Montana State Water Conservation Board for the "Hysham Bench Water Users Association." Water for these canals will be supplied by pumping from Yellowstone River. The main pump station is near the railroad station of Myers in Section 21, T6N, R35E, and a relift station is located about one mile east of the primary one. Project lands include all, or parts of sections 12, 13, 23 and 24, T6N, R35E, and sections 7 to 21, T6N, R36E, and sections 7, 8, 18 and 19 in T6N, R37E (Map 1).

Background

In 1947, or early in 1948, the Montana State Water Conservation Board began the construction of works to make irrigation water available to about 7,500 acres in the vicinity of Hysham. This project is being constructed by the State Board under contract with the Hysham Bench Water Users Association. This corporation, formed by the landowners and prospective water users, will operate and maintain the project.

The irrigation works, as constructed by the State Water Conservation Board, consist of a power transmission line, pumping plants to raise water from Yellowstone River, together with main canals to deliver water to the area. This initial project does not include any lateral ditches or structures to deliver water to the farms, except for those turnout structures from the main canals which will deliver water directly to adjacent lands. The State project includes no survey or plan for water distribution and disposal.

In April, 1948, representatives of the Hysham Bench Water Users Association requested the Treasure County Soil Conservation District to assist the landowners in preparing a plan for a distribution system for their project as a necessary part of the conservation plan and program of the District. To comply with that request the Governing Body of the Soil Conservation District requested technical assistance from the Soil Conservation Service. Under established Federal Policy, technical assistance is available to Soil Conservation Districts from the Soil Conservation Service in planning conservation works and measures. Therefore, a Report of Preliminary Examination was prepared in June, 1948, and in August the Regional Office (Soil Conservation Service) approved the study and directed that a Survey Report be prepared which would set forth a plan for ditches and structures to distribute irrigation water to the project and dispose of excess surface waters.

During the late summer, fall and winter, field surveys were made and maps and other records were prepared. In the spring and summer of 1949 plans were developed and this report assembled.

The State Water Conservation Board anticipates that its main

project will be completed this year and that water will be available to the lands in 1950.

PURPOSE AND SCOPE OF REPORT

This report is directed to the specific purpose of assisting the Treasure County Soil Conservation District and the Hysham Bench Water Users Association in working out measures which will facilitate the development of conservation farming in this area under irrigation. Within its limitations it sets forth a plan designed to shorten the time of development which must elapse before profitable production under irrigation can be realized. The plan is further guided by the requirement of reducing the cost of project development to the lowest figure, consistent with satisfactory operation and conservation of the land and water resources.

The particular purpose of the report is to present a plan for distribution of irrigation water from the canals of the project, and for disposal of excess surface water. The plan is intended to cover, generally, all essential requirements which such a system should meet. It does not include detailed design of ditches or structures, as these must be based on construction surveys. However, the plan shows the location of all ditches. It also indicates fairly closely the number, size and kinds of structures that will be required. Thus, it provides a basis for an approximate estimate of cost, as presented herein, and further gives information in sufficient detail to provide a basis for the preparation of construction plans and specifications for contracting the work of construction.

It is anticipated that details of location will be changed by

final surveys to meet special local conditions. Some features of the plan are presented with alternative treatments suggested, the choice between such alternatives being left for later determination. This report aims to set forth certain conditions that must be met if adequate irrigation service is to be provided to these lands. It shows a plan of ditches and structures designed to meet these conditions. Any modification of this plan, developed with construction, which meets the required conditions, will be equally satisfactory, but if primary conditions are not met adequately, the result will be loss to the landowners, delay in project development, and, worst of all, loss of irreplaceable land resources.

The problem of planning the preparation of this project for irrigation is complicated by the fact that occasional flash floods from hillside water courses cross the area. The system for disposal of excess surface water is planned to handle waste irrigation water and storm runoff from the Project lands. It leaves largely unsolved the problem of disposing of flood waters from outside the project. However, the plan recognizes this problem, and makes such adjustment to the conditions as seems economically practicable as part of the irrigation system.

This report does not, and is not intended to, present engineering plans for construction. The preparation of such plans and engineering supervision of construction are considered to be parts of the construction.

This report has been prepared for the primary and immediate purpose of setting forth a plan for ditches and structures to distribute and dispose of water. It must be assumed that conservation irrigation

irrigation plans, however, will be applied to the lands: The pay-off of an irrigation enterprise is on the farms. Therefore, this report is based, fundamentally, on the proper development of the lands. In and for its preparation basic data have been assembled which are essential to the working out of conservation farm plans under irrigation. Among such data are large scale topographic maps which are available in the Soil Conservation District office at Hysham, and a complete conservation survey with special interpretation of soils and land conditions to irrigation which will be presented as a supplement to the present report.

While this report is directed primarily to local people who are familiar with the area, a brief general description is included for the information and orientation of others who may be interested.

GENERAL DESCRIPTION OF THE AREA

Climate

The climate is characteristic of the northwestern plains, although modified to some extent by the Rocky Mountains some 150 miles toward the west. Rather cold winters, hot summers and generally deficient, but highly variable, rainfall are salient features.

Weather records are available for a station at Hysham for only the past three years - 1946, 1947 and 1948. However, these records correlate fairly closely with longer records for Miles City and Forsyth to the east and for Billings, Ballantine and Custer to the west. From these records a fair picture of weather conditions at Hysham may be drawn.

Precipitation for "water years", ending September 30, show an

estimated "normal" of 12.0 inches, related to a base 30-year period, 1910 to 1939. Variation from this normal, ranging to nearly 50 per cent either way, may be anticipated for any particular year. The record of annual precipitation for the three years at Hysham with percentages of normal is as follows: 1946, 16.12" - 134%; 1947, 11.23" - 94%, and 1948, 12.79" - 107%. About 75 per cent of the annual precipitation generally occurs during the warm six-month season, April through September, May or June generally having the greatest monthly rainfall.

Temperatures are generally lower in the winter and higher in the summer than in western Montana. Extremes of lower than -40° and higher than 105° have been recorded in the general vicinity.

The Frost-Free Period probably averages about 140 days. At Ballantine, some 50 miles up the valley, a 29-year record shows an average of 137 days, from May 10 to September 24. The shortest period recorded was 89 days in 1930, and the longest, 180 days, in 1940. In only four of the 29 years was the frost-free period less than 120 days.

With irrigation, the climate is adapted to a fairly wide range of crop diversification.

Soils

Practically all soils found in the project are adaptable to high development under irrigation. Intensity of treatment will vary, and capabilities of some of the lands are more or less limited. Such differences in capabilities and in treatment of different lands are recognized but they do not materially affect the layout of the project irrigation system which is the primary subject of this report.

The main part of the report is presented, therefore, without an analysis of land conditions.

Informed recognition of the different capabilities and of different practices on or treatment of different lands, however, is vital to the development of farms and farm irrigation systems. Therefore, a detailed classification has been made of all project lands. This will be presented, together with full interpretation and discussion in a supplement to this report which is being prepared. It could not be completed earlier and will be presented separately to avoid longer delay in presentation of this report.

Topography

From the hills, which bound the project on the south, the land slopes down generally toward the north to a rather abrupt terrace break below which more gentle slopes extend down to the river flood plain. East of Hysham, the Yellowstone ditch approaches the terrace break and project lands are practically all on the terrace and foot-slopes. West of Hysham the terrace break of 20 to 30 feet or more in elevation divides the project lands. This break extends irregularly southwestward from Hysham to "Buckingham Coulee", a large flood-water course which dissects the western end of the project. West of Buckingham Coulee there is little or no terrace conformation, colluvial slopes extending from the foot of the hills to the river. The face of the terrace is cut by numerous draws or coulees which finger out into the terrace lands above.

Special Features of the area involve flood drainage from the high lands south of the project. Three definite water courses cross the project. "Sarpy Creek" near the east end is a considerable

stream although it probably does not flow during dry periods. It has a well-established, fairly stable channel across the project.

"Box Elder Creek" crosses the project from south to north, crossing the highway and railroad just west of Hysham. This is a "dry stream", subject to occasional flash floods of short duration but of considerable intensity. It drains an area of about 30 square miles, outside the project.

"Buckingham Coulee", from a drainage area of a little over five square miles, crosses near the west end of the project. It, like Box Elder Creek, is a flash-flood water course, but, in contrast to the former, is deeply entrenched and is subject to much more frequent and more intense flash floods.

Cultural Features of the Area

Hysham, the County Seat of Treasure County, is a progressive town of about 500 population. It provides unusually good cultural and commercial services for a town of its size. It is on the main line of the Northern Pacific Railroad and U. S. Highway No. 10.

Telephone and electric power services are available to the entire project area. Adequate county roads provide ready access to the highway and to Hysham.

Agriculture

Practically the entire project area has been limited to dry farming. Wheat has been the principal crop, with yields ranging from excellent to poor depending on the amount and timeliness of rainfall. Essentially, all of the lands have proven to be highly productive when adequate moisture is available.

North of the project are lands irrigated from the Yellowstone

Ditch and by individual pumping plants. On these lands a very successful diversified agriculture has been developed. Principal crops include alfalfa, sugar beets, beans, corn and seed crops. Flood-plain lands along the Yellowstone include waste areas in sloughs and breaks but provide some pasture.

BASIC DATA AND MATERIAL AVAILABLE

During the fall and winter of 1948 a topographic survey was made of the project area. Field maps were prepared on a scale of one inch equal to 300 feet and these maps were finished and duplicated. Copies of these are available at the Soil Conservation Service office in Hysham. A photo-reduction was made of the field maps to a scale of one inch equal to 1000 feet and the maps were prepared which accompany this report.

A conservation survey was made of the lands of the area, with exploratory borings of the soil, subsoil and substrata. Information obtained by this survey has been considered, as far as it affects the project plan: Its interpretation to the development and treatment of farm lands under irrigation will be presented later.

During progress of planning the lateral and distribution system "spot" field inspections were made of special details. All information obtained by the State Water Conservation Board in connection with the main project construction was made available. Close cooperation with engineers of the State Board was maintained throughout the work.

THE DISTRIBUTION-SYSTEM PLAN

Criteria Used and Assumptions Made

The plan has been prepared according to the following criteria:

1. That water be delivered to the high point, or high points, of every present ownership and to every 160 acres, except that an isolated small area in any tract might be left dependent on service from an adjoining tract, through cooperation between farm operators.
2. That the lateral system be designed to deliver water at the point or points on each land-tract which would fit in with the best layout of the future farm-irrigation system.
3. That the system be planned for lowest construction costs, consistent with safe and satisfactory service, in particular regard for non-erosive ditch grades and adequate structures. That property lines and other artificial boundaries be considered only so far as consistent with economy of construction and operation, while giving due consideration to avoidable cutting or damaging of farm lands.
4. That, generally, the lateral system should deliver water through individual measurement to each tract, but that some laterals might be designed for dual service, in rotation, to two small tracts. And, that where a main lateral crosses one tract to supply another, it might be used in rotation and also that it might be used as a farm-supply lateral for the tract crossed, by addition of approved turnout structures on the part of the landowner served.
5. That the capacity of laterals and structures should be sufficient to supply one cubic foot per second for each 40 acres served, with a minimum of one cubic foot per second to any one tract: Capacities of laterals are determined to provide either one cubic foot per second for each 40 acres served by the lateral or the total of minimum service to each of all tracts served, whichever is larger, with a minimum capacity of three cubic feet per second for any project lateral.

The distribution and disposal plans have been made under the general assumption that they will be carried out under specific detailed designs which will meet conditions essential to satisfactory project operation. Primary conditions are: (1) That water shall be conveyed from the main canals in ditches controlled by drop structures so that they will not cut or erode; (2) That water shall be readily available to each farm operator at the high point, or points, of his land; and, (3) That facilities shall be provided for the control and measurement of flow so that water may be distributed equitably to users.

To meet these conditions it is assumed that velocities in lateral ditches will be controlled at two to three feet per second depending on the capacities of the ditches and on the relative stability of the soils. It is further assumed that drop structures will be so designed and so located as to take up excess fall most economically. (The estimate in this report is based on concrete drops of standard designs but satisfactory though less permanent drops may be constructed at lower cost with corrugated pipe or other materials.) It is assumed that drops will be designed and located to act also as checks where needed for turnouts from laterals.

To meet condition (3) it is assumed that gates or other control structures will be installed. Also, that orifice measuring devices will be installed so that water can be measured to each user. Exceptions to this are cases where a small tract in one ownership may be served from another ownership by mutual agreement. Also, cases where two or more small tracts may be served by rotation through one measuring structure.

Layout of the System

Present ownership was delineated on the large scale (1" = 300') topographic maps. A tentative plan was sketched for the farm irrigation system of each tract to determine the best delivery point or points for that tract.

Tracts were grouped according to location, topography and other features to determine the layout of a main lateral or lateral system to best serve each group. And such main laterals were located as guided by criteria for economy of construction and operation. Thus, the design of the entire system was built up from each individual farm or tract.

Location and Capacities of Orifice Turnouts from the main canals were determined by the lateral system as developed. Locations of orifice turnouts for tracts adjacent to the main canals were determined to fit directly into farm distribution systems. The layout of main turnouts was approved by engineers of the State Water Board and turnouts have been installed accordingly. The minimum capacity of any main canal turnout is three cubic feet per second.

Lateral Wasteways were provided for at the ends of laterals, wherever feasible, to provide for disposal of regulatory waste water and surface drainage which might be picked up by the lateral. Laterals from the highline canals were planned for disposal into the lowline canal wherever possible.

Map Description and Nomenclature

Map 1 shows land ownership as of July 5, 1949, outlined in red and identified by numbers. On Map 2 are shown, outlined in contrasting colors, the approximate areas served by each lateral system. These

include the groups of tracts described previously.

Both maps show the lateral system with each main turnout and each lateral identified by a number-symbol. Turnouts from main canals provide for measurement of flow and are designated as "OTO" (orifice turnout). They are numbered consecutively from No. 1 down the high line and then from No. 31 down the low line canal. Measuring turnouts from laterals are not identified by numbers.

Laterals are designated by the letter "L" and the number of the turnout. Sub-laterals or branches of main laterals are identified by numbers and decimals. Combination laterals, those serving as farm-distribution ditches and also for delivery to another tract, are designated "CL".

DESCRIPTION OF DISTRIBUTION SYSTEM

Referring to Map 1 and turnouts and laterals designated as described above, following is a detailed description of the delivery system as planned. Acreages of service, as shown, are approximate estimates only as actual irrigable areas have not been closely determined.

Ownerships are designated by number thus: "#3, #12", etc.

Capacities are shown in cubic foot per second, "cfs".

OTO-No. 1. Near highline station 103: Required capacity 3 cfs.

Direct service to about 28 acres in ownership #3 above the low line canal.

OTO-No. 2. Near highline station 133: Required capacity 4 cfs.

Area served, 93 acres.

Supplies combination lateral CL2-1.

CL2-1 serves as a farm lateral, supplying 55 acres as it passes through ownership #3 above the county road and then crosses the road to serve 6 acres in ownership #3, 29 acres in #4 (4 acres by flume over lowline), and 3 acres in #5 (to be served from #4).

Length: 0.13 mile.

Required capacity: 3 cfs.

Structures: Drops totaling 23 feet; One county road crossing; Two measuring turnouts (or rotation between operators).

OTO-No. 3. Near highline station 163: Required capacity, 5 cfs.

Direct service to 184 acres in ownership #3.

OTO-No. 4. Near highline station 173: Required capacity, 5 cfs.

Area served, 152 acres.

Supplies lateral CL4-1 which serves as farm lateral for 96 acres through #6 and 19 acres through #3, delivers to 7 acres in #9 and through a flume to 30 acres in #9 below the low line canal. This ditch runs straight down the slope for about 2500 feet, then on contour location about 1100 feet to the south line of section 13 and then about 500 feet west along the sectionline to cross the low line canal by flume.

Total length: 0.89 mile.

Structures: 2 measuring turnouts (or rotation); One flume across low line canal; Drops totaling 34 feet; One wasteway (may be made as part of flume).

OTO-No.4a. Near highline station 179: Required capacity, 3 cfs.
Direct service to 9 acres in #7.

OTO-No. 5. Near highline station 191: Required capacity, 3 cfs.
Direct service to 31 acres in #7.

OTO-No. 6. Near highline station 204: Required capacity, 4 cfs.
Direct service to 142 acres in #7.

OTO-No. 7. Near highline station 210: Required capacity, 5 cfs.
Area served, 117 acres.

Supplies laterals L7-1.0 and L7-1.1.

L7-1.0 follows east side of highway 10 and south side county road across Section 19 and across the county road to serve 51 acres in #10, and 26 acres in #7 just below main OTO.

Length: 0.80 mile.

Required capacities: First 1500 feet to L7-1.1, 5 cfs; Next 2500 feet to end, 3 cfs.

Structures: Three measuring turnouts; One county road crossing; Drops totaling 30 feet.

L7-1.1 crosses highway from L7-1.0, follows west side of highway serving 14 acres in #7 and 8 acres in #41, and 18 acres in ownership #11.

Length: 0.38 mile.

Required capacities: Across highway, 4 cfs; Next 1900 feet to end, 3 cfs.

Structures: Drops totaling 16 feet. (No measuring turnouts), (Rotation service between #7, #41 and #11); 3 turnout gates and one highway crossing.

- OTO-No. 8. Near highline station 223: Required capacity, 3 cfs.
Direct service to 122 acres in #41.
- OTO-No. 9. Near highline station 246; Required capacity, 4 cfs.
Direct service to 140 acres in #41 and to 3 acres in #10, north of the county road by cooperation with #41.
- OTO-No.10. Near highline station 270: Required capacity, 3 cfs.
Direct service to 13 acres in #41.
- OTO-No.11. Near highline station 284: Required capacity, 4 cfs.
Direct service to 155 acres in #42.
- OTO-No.12. Near highline station 300: Required capacity, 3 cfs.
Direct service to 16 acres in #43. (#43 is served also from OTO-No. 14 and more than 16 acres may be served from No. 12 if desired).
- OTO-No.13. Near highline station 313: Required capacity, 3 cfs.
Direct service to 10 acres in #44.
- OTO-No.14. Near highline station 321: Required capacity, 16 cfs.
Area served, 642 acres.
Supplies laterals L14-1.0 and L14-1.1.

L14-1.0 follows line between sections 20 and 21 to the county road, then follows east side of county road to waste into the low line canal. It serves 47 acres in #38, 115 acres in #7 and 96 acres in #43, and also supplies L14-1.1.

Length: 1.06 miles, including wasteway to low line canal.

Required capacities: First 700 feet to first turnout, 16 cfs; Next 1300 feet to L14-1.1, 15 cfs; Next 100 feet

across road, 5 cfs; Next 3500 feet to end and including wasteway, 5 cfs.

Structures: One county road crossing; Inlet to low line canal; Drops totaling 36 feet, including wasteway; Four measuring turnouts.

LL4-1.1 crosses county road and runs one-half mile west to serve 370 acres in ownership #10.

Length: 0.49 mile

Required capacities: Across county road, 9 cfs; Next 2500 feet to end, 3 cfs.

Structures: One county road crossing; Drops totaling seven feet.

OTO-No.15. Near highline station 322: Required capacity, 3 cfs.

Direct service to 56 acres in #44.

OTO-No.16. Near highline station 342: Required capacity, 2 cfs.

Area served, 64 acres.

Supplies lateral CEL6-1 which follows the west side of Box Elder Creek through section 21, crossing a county road directly below the canal and another county road to serve 34 acres in #7. As a combination lateral it serves 30 acres in #44.

Length: 0.42 mile.

Required capacity: 3 cfs.

Structures: One measuring turnout (or rotation); Two county road crossings; Drops totaling 12 feet.

OTO-No.17. Near highline station 373: Required capacity, 3 cfs.

Direct service to 16 acres in #45.

OTO-No.18. Near highline station 387: Required capacity, 12 cfs.

Area served, 453 acres.

Supplies laterals L18-1.0 and L18-1.1.

L18-1.0 runs north along the east side of the county road between sections 15 and 16 and east on the midline of section 15 to serve 25 acres in #7 above the low line canal. It serves, also, 112 acres in #37, 40 acres in #36, 164 acres in #7, (7 acres are west of a county road, in the SE1/4 of Section 16) and supplies lateral L18-1.1.

Total length: 0.82 mile.

Required capacities: First 200 feet to first turnout, 12 cfs; Next 1400 feet to third turnout, 8 cfs; Next 1200 feet to L18-1.1, 6 cfs; Next 1500 feet to end, 5 cfs.

Structures: One county road crossing; Five measuring turnouts; One control gate; Drops totaling 29 feet.

L18-1.1 diverts from L18-1.0 near the east one-quarter corner of section 16 and follows a contour location west, approximately along the line between ownerships #7 and #40 to serve 21 acres in #38 and then turns north along the west side of the county road in a wasteway discharging into the low line canal. It serves, also, 79 acres in #40 and 12 acres can be served in #39, through cooperation with ownership #40.

Length: including wasteway, 0.87 mile.

Required capacity: 3 cfs.

Structures: One measuring turnout; Two county road

crossings; Drops totaling 12 feet (including wasteway);
Inlet from wasteway to low line canal.

- OTO-No.19. Near highline station 424: Required capacity, 3 cfs.
Direct service to 18 acres in #35 and 3 acres which may
be served in #37 through cooperation with #35.
- OTO-No.31. Near lowline station 95: Required capacity, 3 cfs.
Direct service to about 10 acres in #3.
- OTO-No.31a. Near lowline station 115: Required capacity, 3 cfs.
Direct service to 72 acres in #5.
- OTO-No.32. Near lowline station 115: Required capacity, 3 cfs.
Direct service to 11 acres in #4.
- OTO-No.33. Near lowline station 137: Required capacity, 3 cfs.
Direct service to 48 acres in #5.
- OTO-No.34. Near lowline station 152: Required capacity, 3 cfs.
Direct service to 24 acres in #3.
- OTO-No.35. Near lowline station 202: Required capacity, 3 cfs.
Direct service to 30 acres in #9.
- OTO-No.36. Near lowline station 247: Required capacity, 3 cfs.
Direct service to 15 acres in #11.
- OTO-No.37. Near lowline station 259: Required capacity, 5 cfs.
Area served, 156 acres.
Supplies combination lateral CL37-1 which passes through
ownership #12 in which it serves 118 acres and delivers
water to 38 acres in #11.

Length: 0.34 mile.

Required capacity, 5 cfs.

Structures: One measuring turnout (or rotation);

Drops totaling 6 feet.

OTO-No.38. Near lowline station 289: Required capacity, 4 cfs.

Area served, 137 acres.

Supplies combination lateral CL38-1 which runs along the east side of and then across ownership #11, in which it serves as a farm lateral, supplying 103 acres in #11 and passes on to serve 34 acres in #13.

Length: 0.55 mile.

Required capacity: 4 cfs.

Structures: One crossing of Highway No. 10; one measuring turnout (or rotation); Drops totaling 6 feet.

OTO-No.39. Near lowline station 289: Required capacity, 3 cfs.

Direct service to 30 acres in #10.

OTO-No.40. Near lowline station 314: Required capacity, 3 cfs.

Direct service to 53 acres in #10.

OTO-No.41. Near lowline station 326: Required capacity, 6 cfs.

Total acreage, 183.

Supplies lateral L41-1.0 and combination lateral CL41-1.1.

L41-1.0 runs 300 feet north to the property line between #10 and #7, where it supplies CL41-1.1; then west 2500 feet to serve 20 acres in ownership #13; then west and northwest across Highway 10 to serve 58 acres in #13.

Length: 0.57 mile.

Required capacities: First 300 feet to CL41-1.1, 6 cfs; Next 2600 feet to end, across Highway No. 10, 3 cfs.

Structures: One crossing of U. S. Highway 10; One measuring turnout; One plain turnout; Drops totaling 8 ft.

CL41-1.1 serves 90 acres while crossing ownership #7 and serves 15 acres in #14.

Length: 0.27 mile.

Required capacity: 3 cfs.

Structures: One measuring turnout (or rotation); Drop totaling 8 feet.

OTO-No.42. Near lowline station 338: Required capacity, 3 cfs.

Direct service to 15 acres in ownership #10.

OTO-No.43. Near lowline station 353: Required capacity, 13 cfs.

Area served, 410 acres.

This turnout supplies lateral L43-1 which runs north along the west side of the county road to about the east quarter-corner of Section 8, near Hysham, serving ownerships #7 - 60 acres, #14 - 100 acres, #17 - 55 acres and #15 - 83 acres, turns west to serve ownership #17 - 35 acres - north across Highway No. 10 to serve #7 - 3 acres and #18 - 85 acres, southwesterly along the highway and west to serve #16 - 27 acres - and ends with 700 feet of wasteway to D5.0.

Length: 2.05 miles, including wasteway.

Required capacities: First 500 feet to first turnout, 13 cfs; Next 1400 feet to next turnout, 11 cfs; Next 1400 feet to next turnout, 9 cfs; Next 1400 feet to next turnout, 8 cfs; Next 5500 feet to end, including wasteway, 5 cfs.

Structures: Eight measuring turnouts; One county road crossing; One highway crossing; One culvert under disposal channel D5.0 and Drops totaling 41 feet. Design of the crossing under disposal channel D5.0 and of the wasteway will have to be worked out with design of D5.0.

OTO-No.44. Near lowline station 354: Required capacity, 2 cfs.
Direct service to 47 acres in ownership #38.

OTO-No.45. Near lowline station 374: Required capacity, 6 cfs.
Total acreage, 167.

Supplies lateral L45-1 which serves 37 acres in #38, east of Box Elder Creek, follows the east bank of Box Elder Creek northwesterly to serve 20 acres in #17 and 38 acres in #21, then runs north between ownerships #17 and #21 to serve 72 acres in #15, and through a wasteway to Box Elder Creek.

Total length: including wasteway, 0.72 mile.

Required capacities: First 100 feet, 6 cfs; Next 1800 feet, 5 cfs; Next 1500 feet to end, 3 cfs.

Structures: Four measuring turnouts; Drops totaling 16 feet (including wasteway).

OTO-No.46. Near lowline station 382: Required capacity, 5 cfs.

Total area served, 144 acres.

Supplies lateral L46-1 which runs north along the east side of the county road serving 66 acres in #39, 39 acres in #19 and 39 acres in #15.

Total length: 0.51 mile.

Required capacities: To first turnout, 5 cfs; First 1300 feet to next turnout, 4 cfs; Last 1400 feet to end, 2 cfs.

Structures: Three measuring turnouts; One county road crossing; Drops totaling 14 feet.

OTO-No.47. Near lowline station 409: Required capacity, 11 cfs.

Area served, 338 acres.

Supplies combination lateral CL47-1.0 with sub-laterals L47-1.1, L47-1.2 and L47-1.3.

CL47-1.0 runs north along the west side of the county road to feed L47-1.1 and L47-1.2 at the southwest corner of section 10, then westerly on contour location to reach the high point of ownership #19, thence north, following the top of a ridge, as a combination lateral serving 37 acres in ownership #19 and 38 acres in #15, to a high point covering 20 acres in #20, and thence west to serve 56 acres in ownership #21 and wasting into disposal channel D9.0. Seven acres in #20 will have to be served from ownership #15.

Length: 1.02 miles.

Required capacities: First 1100 feet to L47-1.1, 10 cfs; Next 2200 feet, across ownership #19, 5 cfs; Next 1400 feet, across ownership #15, and last 700 feet to end, 4 cfs.

Structures: Four measuring turnouts; One control gate; One county road crossing; One cross-drainage culvert; Drops totaling 17 feet.

L47-1.1 runs east from the southwest corner of Sec. 10 approximately along a property line but on a contour location to reach two high points in #22 and one in #24, crossing disposal channel D-11. It should cross this channel with a controlled spillway structure diverting D-11 to L47-1.3 and to the end of L47-1.1. It serves 78 acres in #22 and 22 acres in #24 and also supplies L47-1.2 and L47-1.3.

Length: 0.61 mile.

Required capacities: Across county road to L47-1.2, 7 cfs; First 2200 feet to L47-1.3, 4 cfs; Last 1000 feet to end, 3 cfs.

Structures: Four measuring turnouts; One county road crossing; One controlled spillway structure; Drops totaling 8 feet.

L47-1.2 runs north on the east side of a county road to cross another road and serve 20 acres in ownership #20.

Length: 0.26 mile.

Required capacity: 3 cfs.

Structures: One county road crossing; Drops totaling 9 feet.

L47-1.3 diverts from L47-1.1 and disposal channel D-11 near the south quarter-corner of Section 10 and runs northeast to a high point in ownership #24, then north and west to cross a county road and reach a high point in #25. This lateral serves 14 acres in #24 and 46 acres in #25.

Length: 0.49 mile.

Required capacity: 4 cfs.

Structures: One measuring turnout; one county road crossing; Drops totaling 9 feet.

OTO-No.48. Near lowline station 415: Required capacity, 3 cfs.

Direct service to 44 acres in ownership #37.

OTO-No.49. Near lowline station 428: Required capacity, 4 cfs.

Direct service to 129 acres in ownership #7.

OTO-No.50. Near lowline station 447: Required capacity, 3 cfs.

Direct service to 10 acres in ownership #35.

OTO-No.51. Near lowline station 459: Required capacity, 6 cfs.

Area served, 236 acres.

Supplies laterals L51-1.0 and L51-1.1.

L51-1.0 runs north along the east side of a county road, serving 16 acres in ownership #33, 100 acres in #34, 38 acres in #23 where it supplies lateral L51-1.1, then extends north to cross a county road to serve 32 acres in #25. A wasteway along the north side of the county road discharges into a deep draw.

Length: including wasteway, 1.02 miles.

Required capacities: First 700 feet (between first and second turnouts), 5 cfs; Next 2700 feet to L51-1.1, 4 cfs; Next 1300 feet to end, 3 cfs.

Structures: Five measuring turnouts; One county road crossing; Drops totaling 32 feet, including wasteway.

L51-1.1 diverts from L51-1.0 on the property line

between #34 and #23 and runs east one-quarter mile to serve 50 acres in ownership #27.

Length: 0.25 mile.

Required capacity: 3 cfs.

Structures: Drops totaling 6 feet.

OTO-No.52. Near lowline station 477: Required capacity, 3 cfs.

Direct service to 20 acres in ownership #33.

OTO-No.53. Near lowline station 487: Required capacity, 11 cfs.

Total area served, 429 acres.

Supplies laterals L53-1.0 and L53-1.1.

L53-1.0 runs north along a property line, serving 56 acres in #34, supplying L53-1.1, serving 17 acres in #27 south of a county road and 6 acres in #27 and 125 acres in #26 north of that county road. A wasteway extends about 500 feet beyond the last turnout.

Length: including wasteway, 0.93 mile.

Required capacities: First 200 feet to turnout, 11 cfs; Next 1400 feet to L53-1.1, 9 cfs; Next 1300 feet, to turnout, 5 cfs; Last 2000 feet to end, 4 cfs.

Structures: Four measuring turnouts; One County road crossing; Drops totaling 42 feet, including wasteway.

L53-1.1 diverts from L53-1.0 on a property line and runs east one-half mile, serving 158 acres in #19 and 67 acres in #28, wasting into disposal channel D-15.2.

Length: 0.51 mile.

Required capacities: First 800 feet, to turnout, 6cfs; Next 1900 feet, to end, 3 cfs.

Structures: Two measuring turnouts; Drops totaling 6 feet.

OTO-No.54. Near lowline station 490: Required capacity, 3 cfs.
Direct service to 46 acres in ownership #33.

OTO-No.55. Near lowline station 508: Required capacity, 3 cfs.
Direct service to 40 acres in ownership #19.

OTO-No.56. Near lowline station 530: Required capacity, 3 cfs.
Direct service to 40 acres in ownership #32.

OTO-No.57. Near lowline station 549: Required capacity, 3 cfs.
Serves 91 acres in ownership #28 through L57-1.
This lateral consists of only a short section of ditch with drops and a crossing of disposal channel D-15.1.

Length: 0.04 mile.

Required capacity: 3 cfs.

Structures: Drops totaling 23 feet (Pipe drop crossing D-15.1).

OTO-No.58. Near lowline station 564: Required capacity, 3 cfs.
Serves 69 acres in ownership #30 through L58-1 which is a short ditch with drops and crossing of disposal channel D-15.1.

Length: 0.04 mile.

Required capacity: 3 cfs.

Structures: Drops totaling 12 feet (Pipe drop crossing D-15.1).

OTO-No.59. Near lowline station 595: Required capacity, 3 cfs.
Direct service to 15 acres in ownership #31.

OTO-No. 60. Near lowline station 601: Required capacity, 13 to 15 cfs*.

Area served, 470 to 530* acres.

Supplies laterals L60-1.0 and L60-1.1.

L60-1.0 drops straight out from the main canal turnout to elevation about 2667 where it supplies L60-1.1, then follows contour location northwesterly to cross a county road at a high point of ownership #29, then runs west along the north side of the county road nearly three-quarters of a mile, then north along the east side of the county road one-quarter mile, where it turns west across a road to a wasteway extending one-quarter mile west, then north one-quarter mile to serve 100 acres in ownership #26. It also serves one tract of 75 acres and one of 110 acres in #28, 35 acres in #30 and 100 acres in ownership #29.

Length: 1.60 miles, including wasteway.

Required capacities: First 200 feet, to L60-1.1, 13 to 15 cfs; Next 600 feet to turnout across county road, 11 cfs; Next 900 feet, to next turnout, 8 cfs; Next 1400 feet, to next turnout, 7 cfs; Next 2700 feet, to next turnout, 5 cfs; and, Last 1300 feet, to end, 3 cfs (wasteway, 1500 feet of 5 cfs capacity).

Structures: Six measuring turnouts; Two county road crossings; Drops totaling 32 feet, including wasteway.

L60-1.1 diverts from L60-1.0 by continuing the drop from the main canal turnout down to about elevation 2650, then turns southwesterly on a contour location for about

400 feet, then turns northeasterly with a drop to about elevation 2647 across a slough to deliver water to about 5 acres in ownership #46, then north across a county road to serve 30 acres in ownership #29. About 15 acres in ownership #46 may be serviced across #29.

*Owner #46 may divert from L60-1.1 above the slough crossing and serve about 60 acres from this source instead of from main canal turnout OTO-No.61 or OTO-No.70.

Length: 0.23 mile..

Required capacities: First 500 feet, to turnout above slough (if owner #46 elects to serve 60 acres from such turnout), 5 cfs; Last 700 feet, across slough and county road, to end, 3 cfs.

Structures: One measuring turnout; One county road crossing; Drops totaling 19 feet; One slough crossing (may be combined with drop)..

OTO-No.61. Near lowline station 635: Required capacity, 4 cfs.
Direct service to 135 acres, or 65 acres* in ownership #46 and 8 acres in #52, through #46.

*(Nearly half the acreage in #46 might be served from No. 60.--See note on L60-1.1)..

OTO-No.62. Near lowline station 677: Required capacity, 3 cfs.
Direct service to 30 acres in ownership #52.

OTO-No.63. Near lowline station 701: Required capacity, 3 cfs.
Direct service to 50 acres in ownership #53.

OTO-No.64. Near lowline station 717: Required capacity, 3 cfs.

Direct service to 20 acres in ownership #53 and to 15 acres in #54.

OTO-No.65. Near lowline station 742: Required capacity, 3 cfs.

Direct service to 20 acres in ownership #54.

OTO-No.66. Near lowline station 753: Required capacity, 3 cfs.

Direct service to 13 acres in ownership #54.

OTO-No.67. Near lowline station 768: Required capacity, 3 cfs.

Direct service to 40 acres in ownership #53.

OTO-No.68. Near lowline station 807: Required capacity, 3 cfs.

Supplies lateral L68-1 which delivers water across a county road to 80 acres in ownership #53.

Length: 0.04 mile.

Required capacity: For 200 feet, across road, 3 cfs.

Structures: One county road crossing.

OTO-No.69. Near lowline station 836: Required capacity, 4 cfs.

Direct service to 140 acres in ownership #52 and to 10 acres in #46, through #52.

OTO-No.70. Near lowline station 853: Required capacity, 3 cfs.

Direct service to 70 acres in ownership #46. (Additional acreage may be served from No. 70 instead of from No. 60 or No. 61 by fluming across Sarpy Creek.)

OTO-No.71. Near lowline station 874: Required capacity, 4 cfs.

Area served, 111 acres.

Direct service to 11 acres in ownership #51 and supplies lateral L71-1 which crosses a north-and-south county road, runs north along the west side of that road and crosses an

east-and-west county road to deliver water to 100 acres in ownership #46.

Length: 0.19 mile.

Required capacity: 4 cfs.

Structures: One measuring turnout; Two county road crossings; Drops totaling 2 feet (May be combined with road crossings).

OTO-No. 72. Near lowline station 889: Required capacity, 4 cfs. Direct service to 162 acres in ownership #47.

OTO-No. 73. Near lowline station 921: Required capacity, 7 cfs. Area served, 130 acres.

Supplies laterals L73-1.0 and L73-1.1.

L73-1.0 runs north from main turnout along the east side of a county road for about 900 feet, then east along the south side of the road about 500 feet to a measuring turnout to serve 18 acres* in ownership #48 through an existing farm lateral, then north across the county road to supply L73-1.1 and a turnout to serve 52 acres in ownership #47; then north and northeast about 1800 feet to serve 20 acres in ownership #55, then east about 1000 feet to serve 30 acres in ownership #49.

Total length: 0.83 mile.

Required capacities: First 1400 feet, to first turnout, 7 cfs; Next 100 feet, across road, to L73-1.1, 6 cfs; Next 1700 feet, to next turnout, 3 cfs; Last 1000 feet, to end, 3 cfs.

Structures: Five measuring turnouts; One county road

crossing; Drops totaling 30 feet.

*This 18 acres may be served from main turnout No. 74 but use of existing farm ditch would save some drops in farm service to ownership #48.

L73-1.1 runs east, along the north side of the county road, about 2000 feet to serve 10 acres in ownership #49.

Length: 0.39 mile.

Required capacity: For 2100 feet, 3 cfs.

Structures: Drops totaling 3 feet.

OTO-No.74. Near lowline station 938: Required capacity, 3 cfs.

Direct service to 52 acres (or 70 acres--See note under No. 73) in ownership #48.

OTO-No.75. Near lowline station 978: Required capacity, 4 cfs.

Direct service to 145 acres in ownership #49.

Summary of Distribution System:

Total OTO's from main canals -- 66 (Installed by State Water Board)

TABLE I

| Approximate TOTALS involved in all lateral ditches as described | | | | | | | |
|-----------------------------------------------------------------|------------------|------------------|------------------------|---------------------------|-----------------------|------------|--|
| Capacity: (cfs) | Length: (Mi.) | Drop in: Feet | Measuring: Turnouts | County Road: Crossings | Highway: Crossings | Other | |
| 2 to 3 | 9.7 | 244 | 60 | 14 | 1 | a,b,10f | |
| 4 to 6 | 6.7 | 157 | 7 | 4 | 3 | c,d,e,7f,x | |
| 7 to 9 | 1.8 | 84 | 1 | 2 | - | 2f | |
| 10 to 12 | 0.7 | 18 | -- | 1 | - | 1f | |
| 13 to 16 | 0.5 | 31 | -- | -- | - | | |
| Totals | 19.4 | 534 | 68 | 21 | 4 | 20 f | |

a. 3 cfs flume across lowline (CL4-1), with spillway.

b. 3 cfs flume, or other crossing of slough (L60-1.1).

- c. Two 6 cfs Inlets to lowline (L14-1.0 and L18-1.1).
- d. Controlled spillway, diverting disposal channel D-11 into L47-1.1 and L47-1.3.
- e. Culvert to carry natural drainage under lateral CL47-1.0).
- f. Farm or private road crossings.
- x. Special designed syphon under D-5.0 (L43-1).

Actual survey and design will doubtless disclose the necessity for additional structures, but may also develop some economies.

Map 2 shows wasteways, "W.W.", at the end of some of the laterals. These are included as parts of such laterals in Table I. It is desirable that all laterals should have outlets at or near the last service turnout to dispose of waste water resulting from regulation.

THE WATER DISPOSAL SYSTEM

Satisfactory disposal of excess and waste water is an essential part of a project distribution system. However, for simplicity, the system of disposal channels is described separately, even though some disposal features are incorporated into the distribution system as described above.

The objectives of the disposal system are to accomplish the following purposes, so far as appear practicable:

- (1) To collect surface waste water from project lands and dispose of it with the least possible damage to lands, irrigation structures, roads and other improvements;
- (2) To reduce to a practicable minimum the damage caused by flood waters from outside the project, crossing project lands; and,
- (3) To conserve water by re-use of as much waste water as

possible through lower irrigation ditches - which can be accomplished largely by disposal of waste water from lands above the lowline canal into that canal for re-use. Other opportunities for conservation of water may be found in diverting from natural drainage ways to irrigation laterals (L47-1.1 and L47-1.3).

On Map 2 proposed disposal channels are shown by bold dashed lines. In some cases it may be noted that such lines follow lateral irrigation ditches. In such a case it is proposed that the irrigation ditch act as a disposal channel. Inlets for waste water into the lowline canal are shown on the map by triangular symbols. Disposal channels are identified by the letter "D" and each channel is further identified by number, as D5-1, D12-1.0, etc.

Channels are also identified according to type. Where an irrigation lateral acts as a pick-up and disposal channel, it is considered as a "pick-up" channel and designated as "PD". Channels that are essentially road-side ditches, which would be established and maintained in cooperation with the County, are identified as "road ditches", "RD". Grassed waterways following natural swales or draws through fields would be essentially parts of the farms and will, necessarily, be maintained by the farm operator, although the Project may participate in their establishment where more than one farm tract is involved: Such channels are designated as "farm disposal", "FD".

Referring to Map 2, each proposed disposal channel shown is described and briefly discussed as follows:

Description of Disposal System

PD-1:

This channel, located in sections 24 and 13, requires that the

part of lateral CL4-1 on contour location be constructed as a one-bank ditch so as to collect surface water. Water collected will be carried across the road and to the wasteway into the lowline canal. No extra construction is involved.

D-2:

Channel D-2 is planned to pick up flood and waste water from four culverts under the lowline canal and conduct it to channel D2-1.

D-2 should probably be designed as a single-bank channel approximately along the south line of section 18, collecting water from both east and west. While it will probably have a gradient near 0.5 per cent, if it is constructed as a grassed waterway, no structural drops should be required.

Length: 0.34 mile; Earthwork, 3000 cu. yds.

Structures: None.

D2-1:

D2-1 would divert from D2 and follow the base of the terrace for about one mile in a northerly direction to cross the Northern Pacific railway through an existing culvert. It would be a one-bank, grassed channel through most of its course with two banks probably being required for about 500 feet at the lower end.

Length: 1.00 mile; Earthwork, 8,000 cu. yds.

PD-3:

This channel would be combined with lateral L7-1.0 running northeasterly from the turnout for L7-1.1, along the southwest side of Highway 10, east along the county road and across the road to the end of L7-1.0. From here an independent ditch would run west along the county road and northeast along the highway to discharge into an existing culvert under the highway.

As there will be drop structures in L7-1.0, provision will have to be made for admitting surface water at appropriate places. Beyond the end of L7-1.0 a small one-bank, grassed ditch should be sufficient.

Length: (of independent channel) 0.17 mile; Earthwork, 600 cu. yds.

Structures: One 3-foot drop (4 cfs); Two 16-foot 12" culvert inlets to L7-1.0; Control structure at end of L7-1.0.

RD4:

This channel would be a roadside ditch on the south side of the county road along the north line of section 20. Near the northwest corner of section 20 it would turn north across the road and follow the top of a steep coulee bank, as a small one-bank ditch, northwesterly to an inlet into the lowline canal. In cooperation with owner #10, this should be designed so that waste water could be used on #10.

Length: Roadside ditch, 1.0 mile; independent channel, 0.38 mile; Earthwork, 1000 cu. yds.

Structures: One 30-foot 15" culvert, across county road; Inlet to lowline canal.

D-5.0:

This disposal channel, located in sections 8 and 9 south and southwest of Hysham, is discussed in considerable detail because it appears to be of primary importance. Its purpose is to pick up waste water below the base of the terrace and conduct it to the railroad bridge about 1.2 miles southwest of Hysham. A primary purpose of this channel is to divert waste and flood water from Box Elder Creek.

Such a channel will have to be carefully designed and located from field surveys. For illustrative and estimate purposes a tentative design and location has been set up from the topographic map and is shown on a plan-profile in the map pocket of this report. This design is planned to accomplish the following purposes:

1. (a) To divert waste water from the draw in the northwest corner of the NEL/4SWL/4 of section 19; (b) pick up waste and flood water from Box Elder Creek in the northwest corner of the NWL/4SWL/4 of section 19; and, (c) intercept waste water along the base of the terrace to the pile bridge on Highway 10 about one mile southwest of Hysham and thence to the railroad bridge.
2. To facilitate farm irrigation service to the SWL/4NWL/4 of section 9 and to include the extension of lateral L43-1 to serve the SWL/4SEL/4 of section 8.

The suggested design is based, generally, on a grassed channel with a cross-section of 40-foot level bottom, 3:1 cut slopes on the upper side and a bank on the lower side having an eight-foot crown and 2:1 side slopes. Depth of the channel, generally, would be four feet, from the grassed bottom to the top of the bank. A gradient of about 0.4 per cent will apparently meet the existing bridges on the highway and railroad from a point near the quarter-corner between sections 8 and 9. With a gradient of 0.4 per cent a grassed channel, as above described, would carry up to 200 c.f.s. without scouring. For very short periods, a flash flood of approximately 1000 c.f.s. might be carried without serious damage. Probably any floods exceeding 200 c.f.s. will be rare and of very short duration.

As tentatively outlined for illustration and estimate, disposal channel D-5.0 would cross the county road with a 24-inch culvert under a low road-grade. All usual flows of both waste water and natural runoff (25 to 30 c.f.s.) would pass through the culvert and the occasional higher flows would pass over the road, as they doubtless have done in the past. If the road-grade were processed with gravel, such overflows would probably cause little damage. For this set-up a drop in grade of two feet is provided. This county road crossing will have to be actually designed in cooperation with the county. Final design will doubtless be changed considerably from the suggested set-up which serves only to illustrate one plan that appears to be feasible.

Below the county road the channel would be located as a "Balance section", equalizing excavation and embankment quantities as nearly as practicable. As noted above, this section is suggested as one with 40-foot bottom with 3:1 slope on the upper side and 2:1 slopes on the embankment, which would have eight-foot crown at elevation of four feet above the bottom.

Quantities involved in construction of D-5.0 would be approximately as follows:

Length: 1.60 miles;

Earthwork: 25,000 cu. yds.;

Structures: Corrugated Culvert Pipe - 24" (road crossing) 40 lin. ft.

Corrugated Culvert Pipe - 15" (Lat.

L43-1) 120 lin. ft.

Alternatives to D-5.1 as suggested above are:

(1) Construction of D-6.1 as a grassed waterway to the highway

bridge west of Hysham, with D-5.0 being only a relatively small ditch collecting excess waters west of Box Elder Creek, and

(2) Construction of a smaller ditch or channel on approximately the same location as above suggested.

Alternative (1) has a serious disadvantage in that there is no outlet for Box Elder Creek water below the highway and railroad. Also, no outlet would be provided for the draw in the NE1/4SW1/4 of section 9.

If a smaller channel were constructed according to alternative (2), occasional flash floods from Box Elder Creek would be a continuing menace to all the lands below and including the town of Hysham. Any reduction in size and capacity would not reduce the cost proportionately.

FD5.1:

This channel is planned as a grassed waterway running north across the N1/2N1/2 of section 17 and the S1/2S1/2 of section 8 to join D5.0. A well-prepared and maintained grass strip some 50 feet wide should hold this channel stable to the point where it breaks down into a deep draw. From this point on it might be maintained with brush plantings but structural drops may be needed to prevent serious head-cutting back into good land.

Establishment and maintenance of this channel will probably be considered as responsibilities of the individual landowners involved.

D6.0:

Disposal channel D6.0 consists of the fairly-well-defined channel of Box Elder Creek. It has been set forth and is discussed as a feature of primary importance to a considerable part of the project.

Responsibility for its treatment, however, may fall largely to individual landowners, with such assistance as may be available from the project organization and State and Federal agencies.

Waste water which will find its way into this channel will doubtless establish a more or less continuous flow. This flow, together with irrigation of adjoining lands, will soften the soil so that occasional flash floods from outside the project may cause very serious damage.

Damage would be evident in the cutting of a gully through nearly three miles of the project. This gully could readily become a "canyon" in a few years if it develops as similar situations have done in other projects. Silt and debris from such erosion of the channel above would be deposited where the water spreads out over the relatively flat "fan" immediately south and west of Hysham. Such silt deposit would be a menace to an ever-increasing area, to the town, the highway and the railroad. If erosion of the upper channel is unchecked, deposit of silt could make the maintenance of any disposal channel such as suggested in D5.0 very difficult and expensive, if not wholly impracticable.

Reasonably complete protection from flood damage by Box Elder Creek would be too costly to be attempted by the project, the community and individuals unless or until cooperation is available with the Federal flood control program. Certain measures, however, can be accomplished by individuals in cooperation with the Project which will reduce immediate damage and at least delay disastrous destruction.

Suggested immediate treatment of this channel is largely vegetative. The lower half-mile of well-defined channel, in the southwest

quarter of section 19, is a shallow draw which appears to be fairly well stabilized at present with grass. Through this reach grass cover should be improved and small brush plantings should be made at any head-cuts that may have developed.

Further south through the northwest quarter and the north half of the southwest quarter of section 16 a definite gully or arroya has developed. Some degree of stability may be established through this reach by bank-sloping and thick brush-planting at intervals.

At the head of this arroya, in the southwest quarter of section 16, a dike-and-drop structure should be installed to stop head-cutting. Such a structure, designed to carry "usual" or frequent floods (up to 250 cfs), might cost \$2,000 to \$3,000.

Above the location of such a drop, a broad grassed channel appears to be fairly stable for a distance of nearly one-quarter mile to the county road on the north line of section 21. South of the road a gully has developed for about 1000 feet. At the head of this gully another drop structure should be installed, similar to the one below. At both suggested drops larger flows could readily be by-passed over grass waterways. Above the upper drop a well-maintained grassed waterway, 200 to 300 feet wide, should extend to the highline canal syphon.

Any work on Box Elder Creek channel should be carefully designed. Suggestions herein are only to illustrate treatment that appears to be possible. Final solution to the problem will doubtless include detention storage at some point or points above the highline canal. Establishment of such works will probably have to await cooperation with the Federal flood control program.

For the immediate future: (1) A complete plan should be worked out from detailed engineering surveys; (2) Farm operators should adapt their land use to that plan and should establish and maintain grass and brush plantings in accordance with the plan; and, (3) Present head-cuts into deep gullies or arroyas should be stopped by appropriate structures.

Total length: 2.0 miles; Earthwork, 5000 cu. yds.

Structures: Two drops and one county road crossing, 80 feet of 48" corrugated culvert.

D6.1:

Water disposal channel D6-1 would be a broad, grassed channel extending from the lower end of the natural channel of Box Elder Creek to the highway bridge west of Hysham. This would be an alternative to construction of channel D5.0 as herein described. This alternative is not recommended unless provision be made to dispose of water below the highway bridge.

Length: 0.47 mile; Earthwork, 2,500 cu. yds.

Structures: One county road crossing; two 40-foot 36" corrugated pipes.

PD7:

Disposal channel PD7 involves only the construction of lateral L18-1.1 as a one-bank ditch designed to admit surface water from the fields above as a wasteway is included in L18-1.1.

FD8:

This channel involves the establishment of an adequate culvert in a draw across a county road in the southeast quarter of section 9 and establishment of a grassed waterway through ownerships #19, #15 and

#20. The culvert would doubtless be installed in cooperation with the county, but it should be designed to take up four to six feet of vertical drop to reduce the gradient in the draw. A grassed waterway can doubtless be maintained by owner #19, but brush plantings may be needed in ownerships #15 and #20.

Length: 0.35 mile; Earthwork, 600 cu. yds.

Structures: 60 feet of 18" corr. culvert with elbow.

D9.0:

This disposal channel is planned to start as a grassed waterway in a swale running north through the S1/2SE1/4 of section 9, cross a county road and extend as a grassed waterway for nearly one-quarter mile from where a constructed channel would carry it under lateral L47-1.0 and north along a property line, through drops to, or across, the Box Elder Canal. The constructed channel should have a capacity of 7 cfs.

Length: Grassway, 2000 feet; Constructed, 1600 feet.

Earthwork: 1,200 cu. yds.

Structures: Drops totaling 8 feet; Crossing under L47-1.0 (30' of 21" corr. pipe with elbow, making 2' to 4' drop); One county road crossing (may be already established).

D9.1:

This channel would start as a roadside ditch along the west side of the county road from near the south one-quarter corner of section 9 to near the center of section 9, at which point it would turn east across the road and extend on a contour location approximately east along a property line to join channel D9.0.

Length: 0.80 mile; Earthwork: 1000 cu. yds.

Structures: Drops totaling 10 feet; One county road crossing.

FD10:

This disposal channel, in the southwest quarter of section 10, involves establishment of a county road crossing, with drop, and establishment and maintenance of a grass-and-brush waterway in a natural draw. The road crossing should provide about four feet of vertical drop. The waterway above (south of) the road would be grass, established and maintained by owner #22; below the road, brush and grass should be established and maintained by owners #20 and #25.

Length: 0.45 mile; Earthwork, 200 cu. yds.

Structures: County road crossing with 4-foot drop, 60 feet 18" corrugated pipe, with elbow.

FD11:

This disposal channel, in the N1/2N1/2 of section 15 and the S1/2S1/2 of section 10, involves establishment of a grass-and-brush waterway in a natural draw. Subject to detailed design, it will include a controlled spillway and diversion structure for the extension of L47-1.1 and for L47-1.3. The grassed waterway should be established and maintained above the spillway structure by owners #37 and #7; Below the spillway, owners #22 and #24 should stabilize the channel by maintaining grass and brush.

Length: 0.67 mile; Earthwork, None.

Structures: (Included with laterals L47-1.1 and L47-1.3).

RD12:

This channel, in sections 10 and 15, runs north along the west

side of a county road and west along the south side of another road to discharge into FD11. This channel would be constructed in cooperation with the County.

Length: 0.90 mile; Earthwork, 2,500 cu. yds.

Structures: Drops totaling about 14 feet.

FD13:

This disposal channel is planned as an extension and wasteway for lateral L18-1.0 along the north line of the N1/2SW1/4 of section 15. For the first quarter-mile it would be L18-1.0, as a pick-up ditch, with a control structure at the end of L18-1.0. It would then extend east one-quarter mile and turn northeasterly to an inlet into the lowline canal; it would be a small (3 cfs), one-bank ditch.

Length: 0.27 mile; Earthwork, 600 cu. yds.

Structures: Control structure at end of L18-1.0.

NOTE: This ditch should be constructed in cooperation with owner #7 who could utilize it as a farm lateral by installing necessary structures.

FD14:

This channel, located in the N1/2S1/2 of section 15, is planned as a grassed waterway in a natural draw through ownerships #35 and #37 to discharge to an inlet into the lowline canal.

No project construction is suggested.

FD15.0:

This channel is planned to start on the south line of the NW1/4NE1/4 of section 13 at a point below a drainage culvert under the lowline canal. From this point it would run west along the property line, or below the canal, for about 3500 feet to the low

point along the south side of the NEL/4NEL/4 of section 14, from where it would turn north and follow the low ground for about one-half mile, to cross a county road and discharge into a natural draw.

The first 3500 feet should be a constructed, grassed waterway with level bottom increasing in width from about 20 to about 100 feet and confined on the lower side by a dike about two feet in height above the bottom. Running north, following the bottom of the swale or draw, the channel should be a level grassed waterway 100 to 150 feet in width. Crossings will be required below CTO-No. 58 and for lateral L57-1. The county road crossing at the end should be designed for a drop of four feet or more.

This channel would be designed and constructed in cooperation with landowners #28, #32 and #30, who would, of necessity, be responsible for its maintenance.

Length: 1.20 miles; Earthwork, 7,000 cu. yds.

Structures: Two farm-service crossings; 80 feet of 15" corrugated pipe; One county road crossing with drop, 60 feet of 21" corrugated pipe.

RD15.1:

Disposal channel RD15.1, located in section 12, is planned as a shallow ditch running west along the south side, north along the west side and, again, west along the south side of a county road to discharge into FD15.0. This channel would be constructed in cooperation with the County.

Length: 1.04 miles; Earthwork, 2,000 cu. yds.

Structures: None.

PD15.2:

This disposal channel would be incorporated in lateral L53-1.1 for about 1800 feet and would be an extension of that lateral for some 800 feet, discharging into D15.0. For L53-1.1 it will involve only arrangements to admit surface water from the upper side at appropriate places and a control structure at the end of L53-1.1. For the rest of the way it might serve as a farm ditch for ownership #28.

Length: 0.16 mile (grassed waterway); Earthwork, 500 cu. yds.

Structures: One control structure at end of L53-1.1.

RD16:

This channel would be a short roadside ditch along the south side of the county road near the center of the SE1/4 of section 11. It would turn north across the road to discharge into a draw. The road crossing should be combined with a drop of about four feet.

Length: 0.15 mile; Earthwork, 300 cu. yds.

Structures: One county road crossing with drop (40 feet of 18" corrugated pipe with elbow).

D17:

This disposal is only a county road crossing at the northwest corner of the NE1/4NE1/4 of section 18.

Length: 0.02 mile; Earthwork, 30 cu. yds.

Structures: 40 feet of 15" corrugated pipe.

FD18.0:

Channel FD18.0, in sections 11 and 14, is planned as a grassed waterway following a natural swale or draw. It would begin near the southwest corner of the SW1/4NW1/4 of section 14, in ownership #33

and run in a northerly direction about one and one-fourth miles across ownerships #34, #27 and #26 discharging to the low terrace above the Yellowstone Canal. It should have a width of at least 100 feet carefully graded and grassed. The lower 1500 feet should be further stabilized by brush-plantings.

Length: 1.30 miles; Earthwork, 3,500 cu. yds.

Structures: One county road crossing with 2-foot drop; 60 feet of 30" corrugated pipe.

RD19:

This is a short channel near the south quarter-corner of section 16. It would run along the west side of a north-south county road, crossing an east-west county road. Design and construction would be in cooperation with Treasure County.

Length: 0.12 mile; Earthwork, 500 cu. yds.

Structures: One county road crossing; 60 feet of 18" corrugated pipe.

NOTE: Alternative design might make the part below the road a combination with a farm-service ditch, in cooperation with owner #7.

D20:

For descriptive purposes, the channel of Buckingham Coulee, across the west end of the project, is designated as D20. It is probable that no great amount of waste irrigation water will reach this channel; however, softening of the land by irrigation and even a small amount of waste water will probably accelerate erosion by the rather frequent flash floods.

When and if flash floods are minimized under the Flood Control

Program, this channel can be stabilized. Meanwhile, every effort should be made to prevent damage arising from irrigation. No part of the coulee bottom should be plowed. Grass and brush planting should be encouraged and every effort made to arrest head-cutting.

Full cooperation with the Flood Control Program should be given, when such a program is put in operation.

Inlets to Lowline Canal:

Inlets for surface water into the lowline canal are essential parts of the water-disposal system. Some of these are outlets for disposal channels described above but many of them would be planned only to admit surface waters which otherwise would collect above the upper canal bank.

These structures may consist of only a length (16 to 24 feet) of corrugated pipe through the upper bank and extending to near the center of the canal.

Most of the appropriate locations for inlets have been located and are shown with triangular symbols on Map 2. Additional inlets may be found to be desirable.

Total Number of Inlets located, 22; Earthwork, 1000 cu. yds.

Materials: 240 feet of 15" and 200 feet of 18" corrugated pipe.

SUMMARY OF WATER DISPOSAL SYSTEM

Water disposal channels and works, as described above, would involve a total length of channels of over 18 miles. Of this, over three miles would be roadside ditch; nearly 2.5 would be in combination with irrigation laterals; about seven miles would be grassed waterways, requiring only grading and seeding, and about six miles

would be constructed channels of various sizes.

In sections of constructed channels, structural drops totaling nearly 50 feet might be required. Twelve county road crossings would be needed; some of these may have been installed by the County. Twenty-two inlet structures would be needed to discharge water into the lowline canal. Three or more control structures for small (3 cfs) ditches would be used.

The construction of the system would involve about 40,000 cubic yards of earthwork, 1500 linear feet of corrugated pipe, ranging from 12 to 48 inches in diameter.

DISCUSSION OF ENGINEERING DESIGN

As stated in "Purpose and Scope", this report does not include engineering design. Such design could be worked out only after detailed surveys are available and, particularly, when other details of construction conditions are known or can be fairly accurately foreseen. The formulation of the general plan shown herein, however, necessarily involved some consideration of types of structures and practicable methods of construction. Furthermore, such consideration was necessary to arrive at some approximate estimate of cost.

Laterals:

Required capacities of ditches has been indicated in the detailed description. It is contemplated that allowable velocities will vary from two to three feet per second, depending on the stability of the soil. This would allow gradients varying from 0.1 per cent for the larger laterals to 0.2 per cent or more for minimum size ditches.

Height and spacing of drops will be determined by the economic

balance between cost of structures and cost of earthwork, with consideration being given also to advantageous location of checks incorporated in drop structures. In combination laterals crossing irrigated fields, it will be desirable generally to increase the number of structures and decrease the drop taken up by each.

Disposal Channels:

Where it is necessary to construct a narrow channel, design would be similar to that for laterals. It is contemplated, however, that in most cases, disposal channels can be planned with relatively wide, shallow sections, protected by grass cover. Such sections may be maintained with gradients of 0.6 per cent, or more. Natural draws may be stabilized with brush and grass plantings at much higher gradients.

Grassed channels on hillside or "contour" location are considered as broad, shallow, one-bank ditches. The width of relatively flat bottom and the height of bank will vary with the volume of water to be carried. Where only waste water and runoff from fields is to be carried, a width of 20 feet or less with a bank or dike two feet, or less, in height will probably be adequate. Where flood water from outside the project must be carried, these dimensions must be increased. The largest channel of this type suggested is that for D5.0 which is suggested to have a bottom width of 40 feet with a bank four feet high. In all cases such channels should have side-slopes as flat as practicable so as to facilitate the use and maintenance of the channel for meadow or pasture.

Grassed channels following the bottoms of swales or coulees are assumed as flat-bottom, or slightly rounded, with very flat side-

slopes, the whole section being graded to blend into the natural contour of the land. In some cases it may be desirable to build low dikes along one or both sides. Construction of these would be essentially a field-leveling or grading operation. In relatively deep, narrow coulees, with heavy gradients, probably little earthwork would be done. In these, natural grass cover should be protected and reinforced with seeding, and brush plantings should be made.

There are many natural draws or coulees from the upper to the lower terrace throughout the project. Their stabilization will present serious problems to some farm operators. Only a few of these have been designated as disposal channels. Stabilization with grass and brush is probably the most generally applicable treatment, as suggested for FD5.1. Where opportunity offers, surface water should be kept out of these draws: Such a measure is illustrated by D4.

Structures:

The general plans herein presented have been based on the general assumption that a rather high-standard, "permanent" type of construction would be adopted. Under this assumption, most lateral structures would be of concrete construction. Most road crossings and some drops would be constructed of corrugated iron pipe with concrete inlets and outlets: Measuring turnouts would be of the orifice type similar to those installed at the main canals. Checks would generally be incorporated in drop structures which would be located immediately below lateral turnouts.

To illustrate the types of some of these structures, some standard plans developed by the Soil Conservation Service are shown on the following pages.

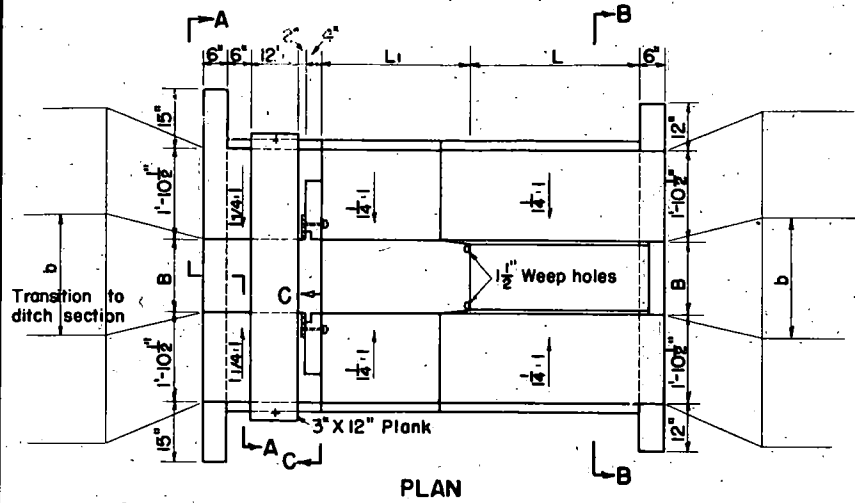

PLAN

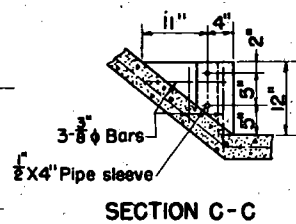

SECTION C-C

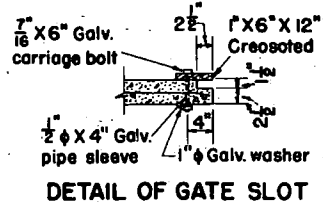

DETAIL OF GATE SLOT

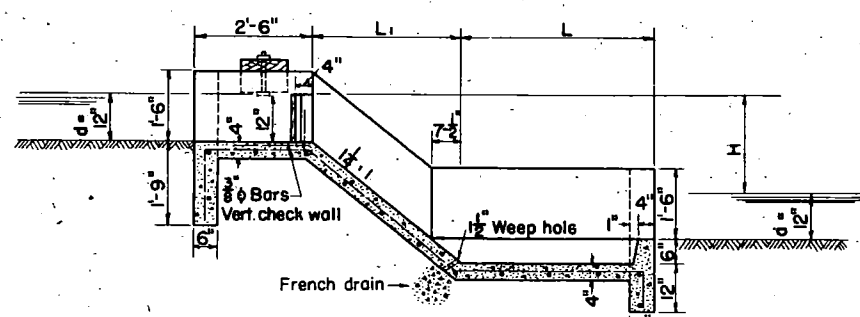
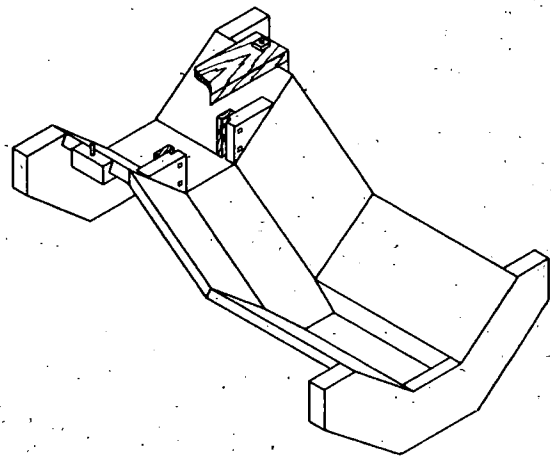

LONGITUDINAL SECTION ON C

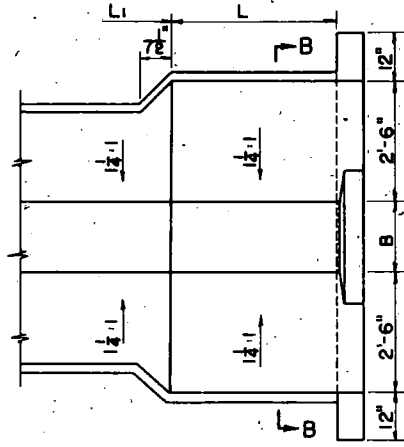

ALTERNATE PLAN OF TRANSITION - CHUTE TO APRON

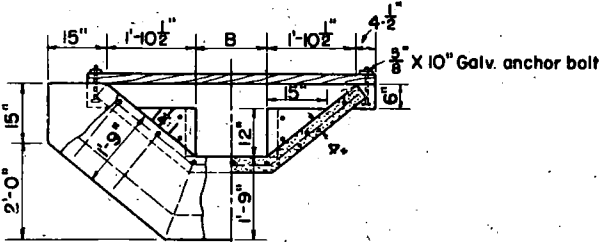

SECTION A-A

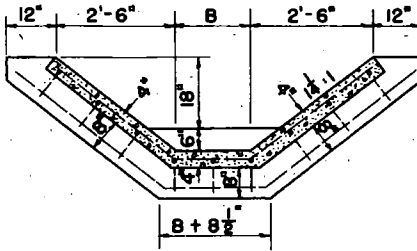

ALTERNATE APRON DESIGN SECTION B-B

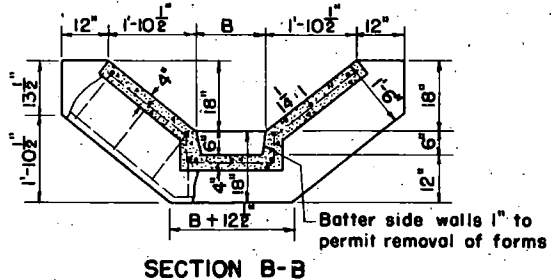

SECTION B-B

TABLE OF DIMENSIONS AND QUANTITIES

| H FT. | L | L ₁ | d=12" B=18" Q=4.33 c.f.s. | | d=12" B=24" Q=5.99 c.f.s. | |
|----------|-------|----------------|------------------------------|-------------------|------------------------------|-------------------|
| | | | CONCR. C.F.T. | STEEL LIN. FT. | CONCR. C.F.T. | STEEL LIN. FT. |
| 1.0 | 2'-6" | 1'-10 1/2" | 28.4 | 163 | 30.3 | 168 |
| 1.5 | 3'-0" | 2'-6" | 31.2 | 179 | 33.4 | 185 |
| 2.0 | 4'-0" | 3'-1 1/2" | 35.4 | 200 | 37.9 | 207 |
| 2.5 | 4'-9" | 3'-9" | 39.0 | 226 | 41.7 | 234 |
| 3.0 | 5'-6" | 4'-4 1/2" | 42.5 | 252 | 45.5 | 260 |
| 3.5 | 6'-3" | 5'-0" | 46.1 | 271 | 49.3 | 280 |
| 4.0 | 7'-0" | 5'-7 1/2" | 49.6 | 291 | 53.1 | 300 |

Q = Capacity of drop = 3.33(B-0.2d)d^{3/2} c.f.s.

NOTES

- Reinforcement in structure to be 3/8" bars placed in center of slabs and spaced 12" c. to c. both ways.
- Lap bars 15" at splices.
- All longitudinal bars to be bent into cutoffs.
- Wire mesh may be substituted if equivalent cross sectional area provided.
- B = Base width of drop
- b = Base width of ditch
- d = Depth of water in ditch
- H = Height of fall in water surfaces
- L = Length of apron
- L₁ = Length of incline

TRAPEZOIDAL CHUTE DROP d = 12"

U. S. DEPARTMENT OF AGRICULTURE
SOIL CONSERVATION SERVICE
H. H. Bennett, Chief
REGION FIVE
LINCOLN, NEBRASKA

| | | | |
|-----------------------|--------|--------------------|---------|
| CARTOGRAPHIC APPROVAL | | TECHNICAL APPROVAL | |
| COMPILED | TRACED | CHECKED | DATE |
| C.J.F. | R.H.B. | C.J.F. | 4-10-47 |
| DRAWING NO. | | DRAWING NO. | |
| 5R-1000.01 | | 5R-1000.01 | |

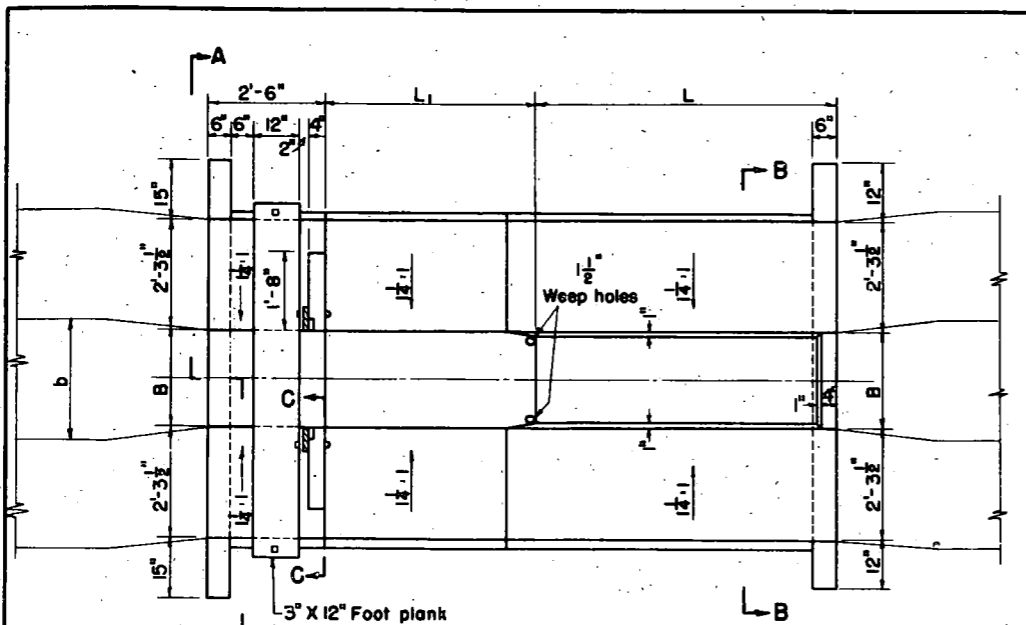

PLAN

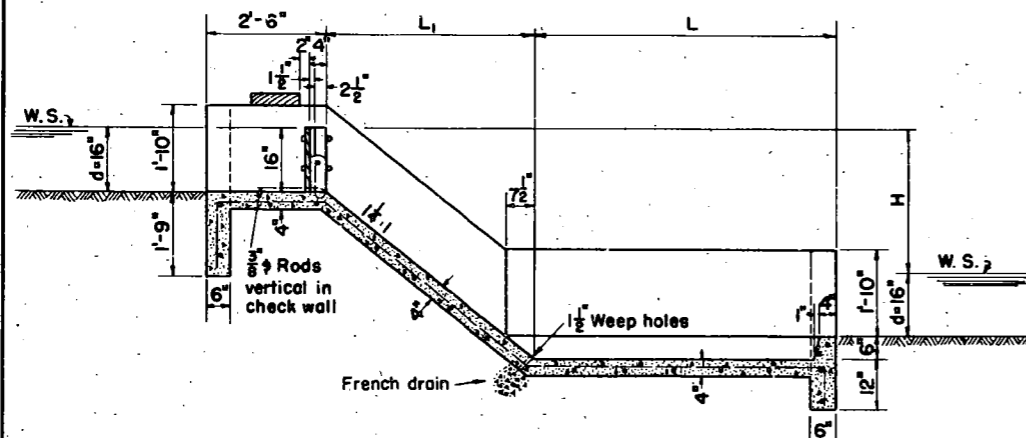

LONGITUDINAL SECTION ON C-C

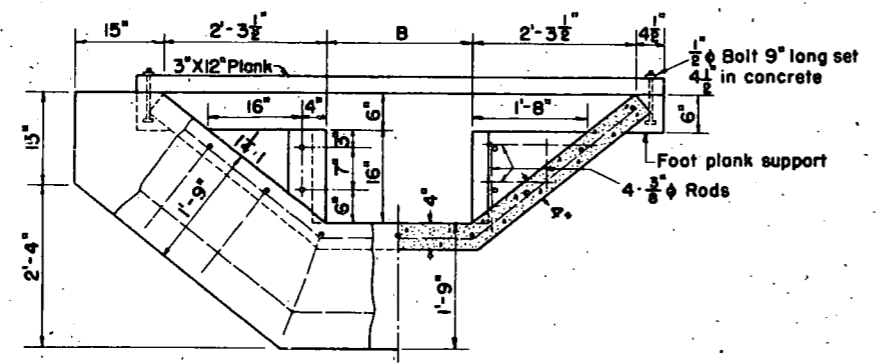

SECTION A-A

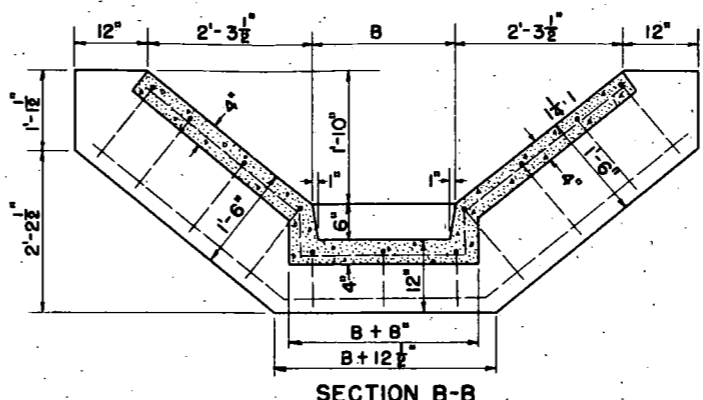

SECTION B-B

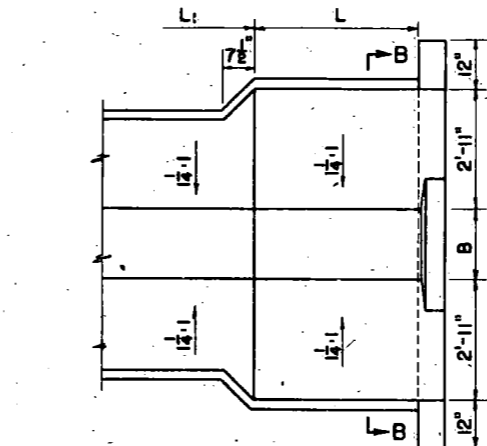

ALTERNATE PLAN OF TRANSITION - CHUTE TO APRON

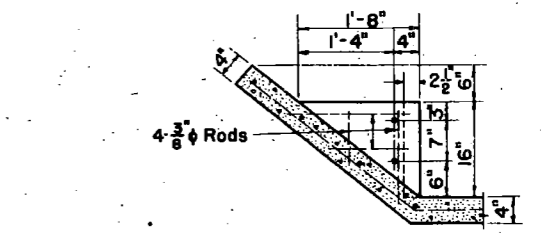

SECTION C-C

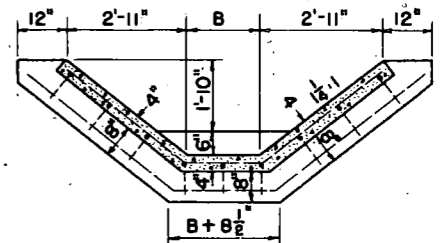
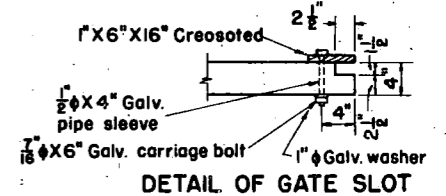

ALTERNATE APRON DESIGN SECTION B-B

TABLE OF DIMENSIONS AND QUANTITIES

| H Ft. | L | L ₁ | d=16" B=18" Q=6.26 c.f.s. | | d=16" B=24" Q=8.81 c.f.s. | |
|----------|-------|----------------|---------------------------|------------------|---------------------------|------------------|
| | | | CONCR. C.F.T. | STEEL LIN.FT. | CONCR. C.F.T. | STEEL LIN.FT. |
| 1.0 | 3'-0" | 1'-10" | 33.8 | 205 | 35.8 | 211 |
| 1.5 | 3'-6" | 2'-6" | 36.9 | 225 | 39.2 | 231 |
| 2.0 | 4'-6" | 3'-1 1/2" | 41.5 | 251 | 44.1 | 257 |
| 2.5 | 5'-3" | 3'-9" | 45.4 | 282 | 48.3 | 290 |
| 3.0 | 6'-0" | 4'-4 1/2" | 49.3 | 312 | 52.4 | 321 |
| 3.5 | 6'-9" | 5'-0" | 53.2 | 337 | 56.6 | 346 |
| 4.0 | 7'-6" | 5'-7 1/2" | 57.1 | 368 | 60.7 | 378 |

Q = Capacity of drop = 3.33(B-0.2d)d^{3/2} c.f.s.

NOTES

- Reinforcement in structure to be 3/8" bars placed in center of slabs and spaced 12" c. to c. both ways. Lap bars 15" at splices.
- All longitudinal bars to be bent into cutoffs.
- Wire mesh may be substituted if equivalent cross sectional area provided.
- B = Base width of drop
- b = Base width of ditch
- d = Depth of water in ditch
- H = Height of fall in water surfaces
- L = Length of apron
- L₁ = Length of incline

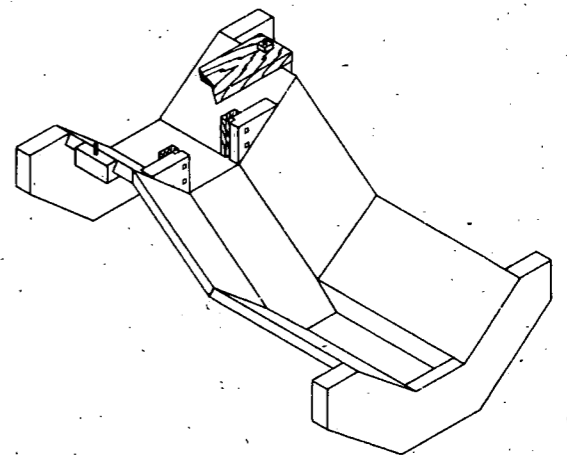

TRAPEZOIDAL CHUTE DROP d=16"

U. S. DEPARTMENT OF AGRICULTURE
SOIL CONSERVATION SERVICE
H. H. Bennett, Chief

REGION FIVE
REFERENCE

CARTOGRAPHIC APPROVAL
COMPILED BY W.R.E. TRACED BY R.H.B. CHECKED BY C.J.F. DATE 4-21-47 DRAWING NO. 5R-10000.02

TECHNICAL APPROVAL
DATE 5R-10000.02

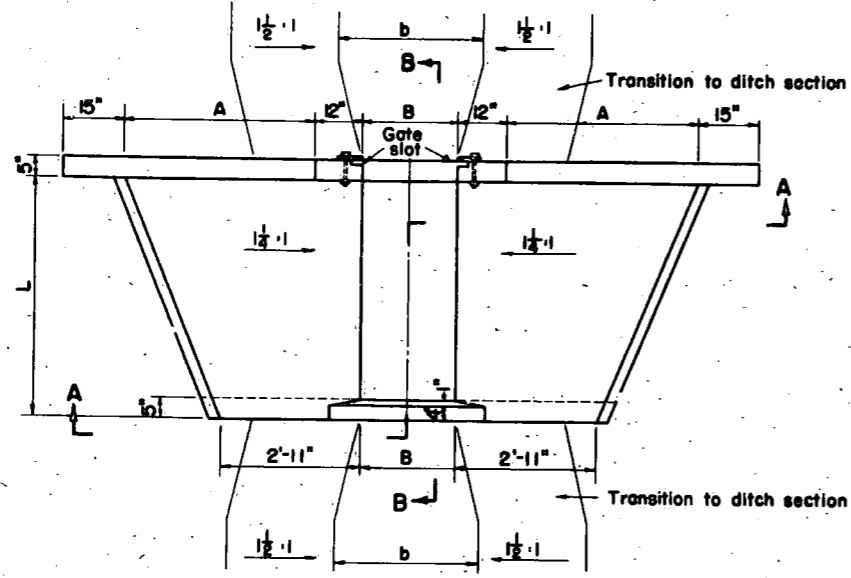

PLAN

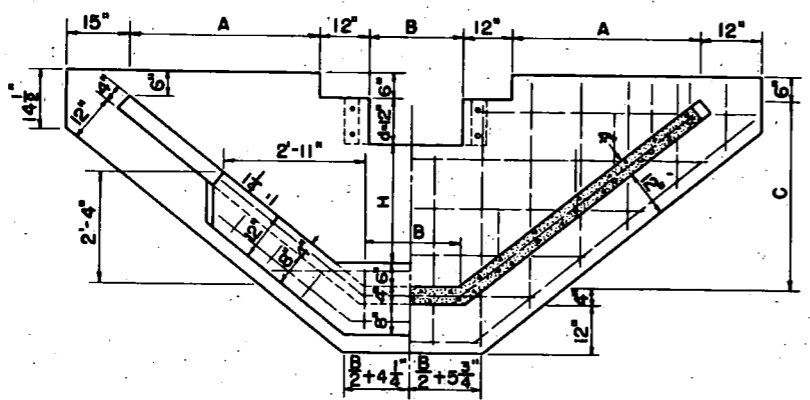

ELEVATION AND SECTION A-A

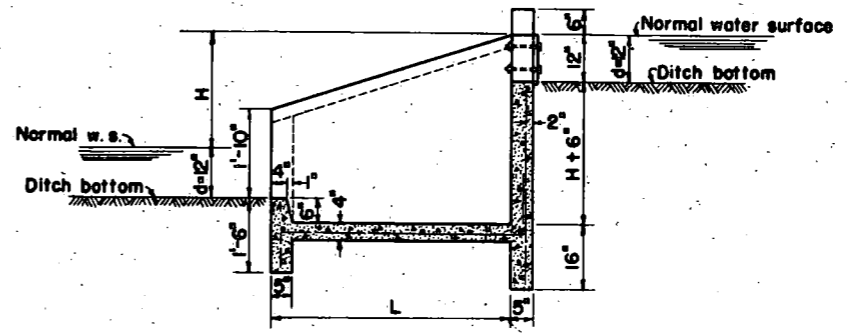

SECTIONAL ELEVATION B-B

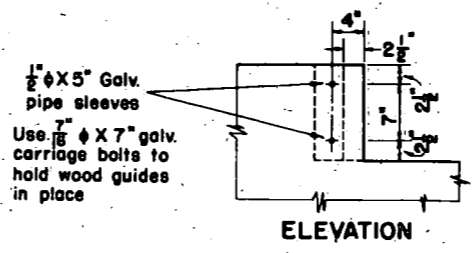

ELEVATION

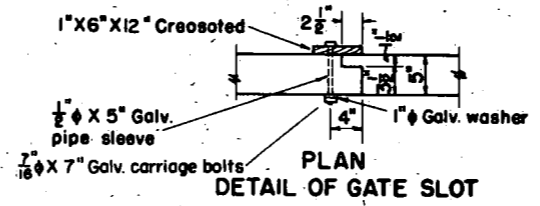

PLAN
DETAIL OF GATE SLOT

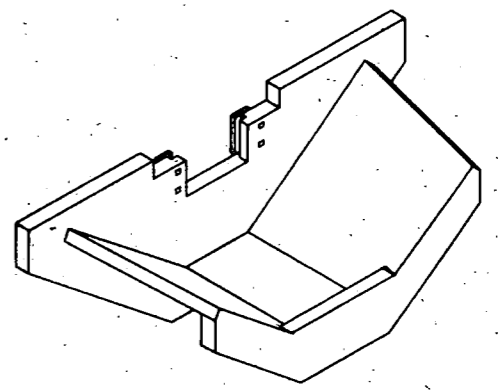

TABLE OF DIMENSIONS AND QUANTITIES

| H Ft. | L | A | C | B=18" | | B=24" | |
|----------|-------|--------|-------|-----------------|-------------------|-----------------|-------------------|
| | | | | CONCR. C.FT. | STEEL LIN. FT. | CONCR. C.FT. | STEEL LIN. FT. |
| 1.0 | 3'-6" | 2'-11" | 2'-6" | 26.4 | 178 | 27.8 | 183 |
| 1.5 | 4'-0" | 2'-9" | 3'-0" | 31.7 | 196 | 33.3 | 201 |
| 2.0 | 4'-6" | 3'-4" | 3'-6" | 37.8 | 243 | 39.6 | 249 |
| 2.5 | 5'-0" | 4'-0" | 4'-0" | 44.7 | 280 | 46.7 | 286 |

Q = Capacity of drop = 3.33(B-0.2d)d^{3/2} c.f.s.

NOTES

Reinforcement to be $\frac{3}{8}$ " rods spaced 12" c. to c. both ways placed in center of slab except where otherwise indicated on plans.
 Lap rods 15" at splices.
 All longitudinal rods to be bent into headwall. Longitudinal rods extending full length to be also bent into downstream cutoff wall.
 Wire mesh may be substituted if equivalent cross sectional area is provided.
 This structure limited to an H of 2.5 ft.
 B = Base width of drop
 b = Base width of ditch
 d = Depth of water in ditch
 H = Height of fall in water surface
 L = Length of apron

VERTICAL TRAPEZOIDAL DROP
 ALTERNATE NO. 1 d=12"

U. S. DEPARTMENT OF AGRICULTURE
 SOIL CONSERVATION SERVICE
 H. H. Bennett, Chief LINCOLN, NEBRASKA

REGION FIVE
 REFERENCE

CARTOGRAPHIC APPROVAL: [Signature]
 TECHNICAL APPROVAL: [Signature]

COMPILED: [Signature] TRACED: [Signature] CHECKED: [Signature] DRAWING NO. [Signature]

W.R.E. R.H.B. W.R.E. 4-28-47 5R10,000.03

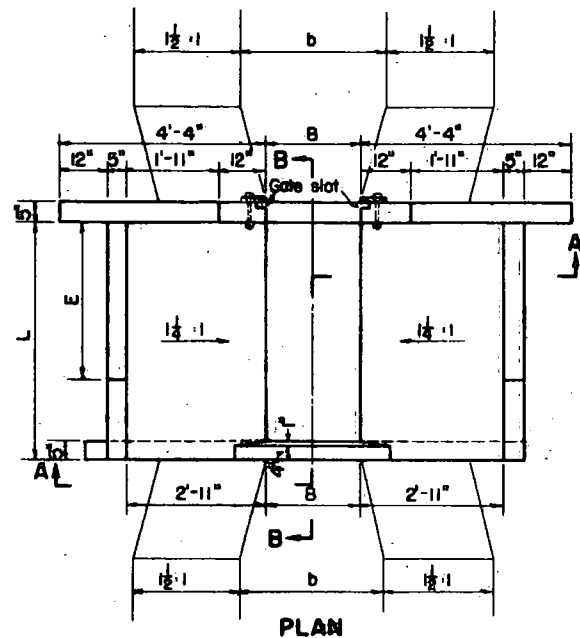

PLAN

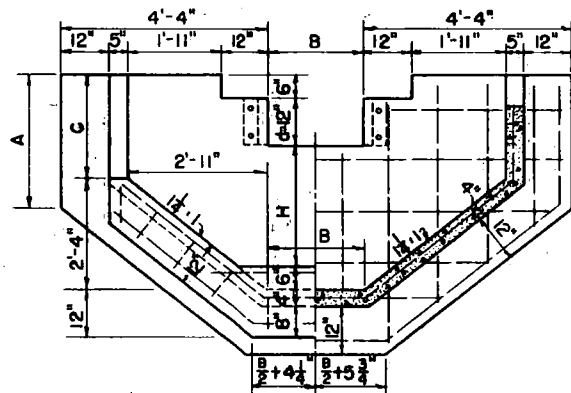

ELEVATION AND SECTION A-A

TABLE OF DIMENSIONS AND QUANTITIES

| H Ft. | L | A | C | E | B=16" Q=4.33 c.f.s. | | B=24" Q=5.99 c.f.s. | |
|----------|-------|-------|-------|-------|------------------------|------------------|------------------------|------------------|
| | | | | | CONCR. C.F.T. | STEEL LIN.FT. | CONCR. C.F.T. | STEEL LIN.FT. |
| 1.5 | 4'-0" | 1'-9" | 1'-2" | 1'-9" | 30.9 | 188 | 32.5 | 193 |
| 2.0 | 4'-6" | 2'-3" | 1'-8" | 2'-6" | 35.4 | 221 | 37.2 | 228 |
| 2.5 | 5'-0" | 2'-9" | 2'-2" | 3'-3" | 40.4 | 236 | 42.3 | 242 |

Q = Capacity of drop = $3.33(B-0.2d)d^{3/2}$ c.f.s.

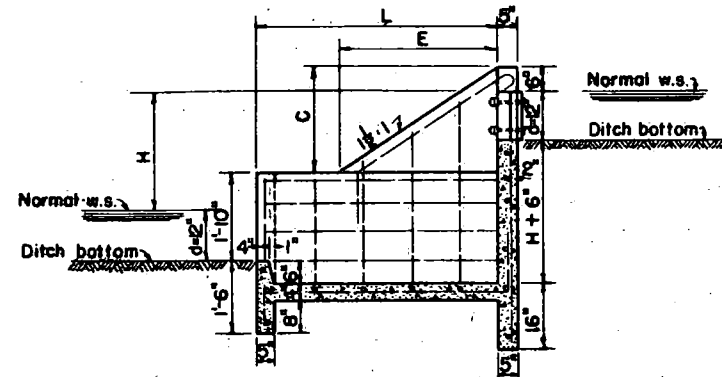

SECTIONAL ELEVATION B-B

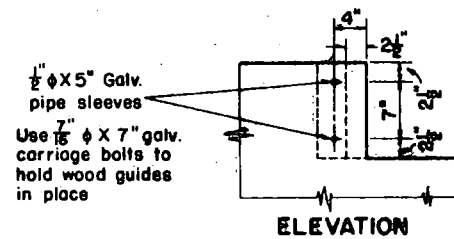

ELEVATION

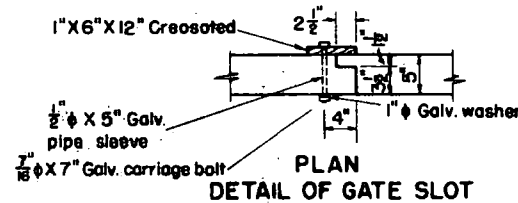

PLAN
DETAIL OF GATE SLOT

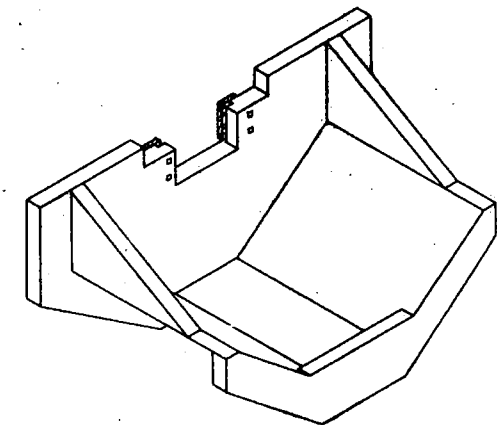

NOTES

- Reinforcement to be $\frac{3}{8}$ " ϕ rods spaced 12" c. to c. both ways placed in center of slab except where otherwise indicated on plans.
- Lap rods 15" at splices.
- All longitudinal rods to be bent into headwall and downstream cutoff wall.
- Wire mesh may be substituted if equivalent cross sectional area is provided.
- This structure limited to an H of 2.5 ft.
- A = Height at end of wing wall
- B = Width of weir crest and bottom of apron
- b = Width of ditch
- C = Height of vertical sidewall at wing wall.
- d = Depth of water in ditch
- E = Length of vertical sidewall
- H = Height of fall in water surface
- L = Length of apron

| | | | | | |
|--------------------------------------------------------------------------------------|--------|-------------------|--------------------|--------------|--|
| VERTICAL TRAPEZOIDAL DROP ALTERNATE NO. 2 d=12" | | | | | |
| U. S. DEPARTMENT OF AGRICULTURE SOIL CONSERVATION SERVICE H. H. Bennett, Chief | | | | | |
| REGION FIVE | | LINCOLN, NEBRASKA | | | |
| REFERENCE | | | | | |
| CARTOGRAPHIC APPROVAL | | | TECHNICAL APPROVAL | | |
| COMPILED | TRACED | CHECKED | DATE | DRAWING NO. | |
| W.R.E. | R.H.B. | W.R.E. | 4-29-47 | 5R-10,000.04 | |

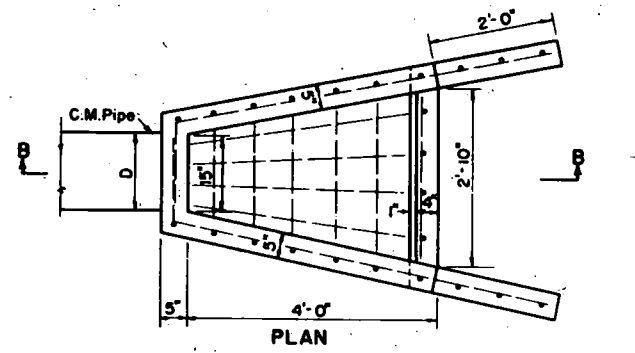
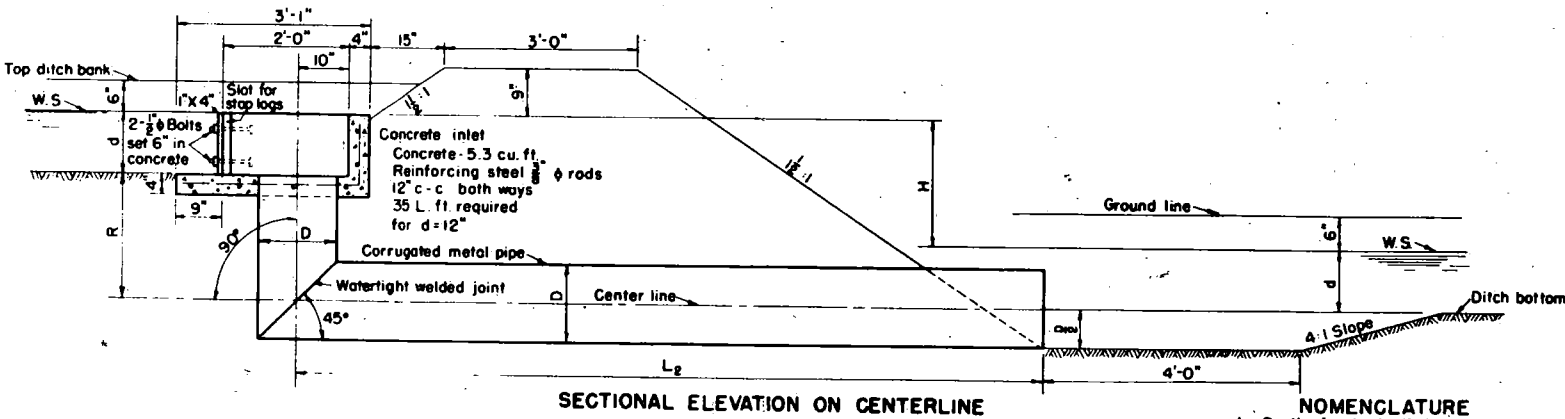
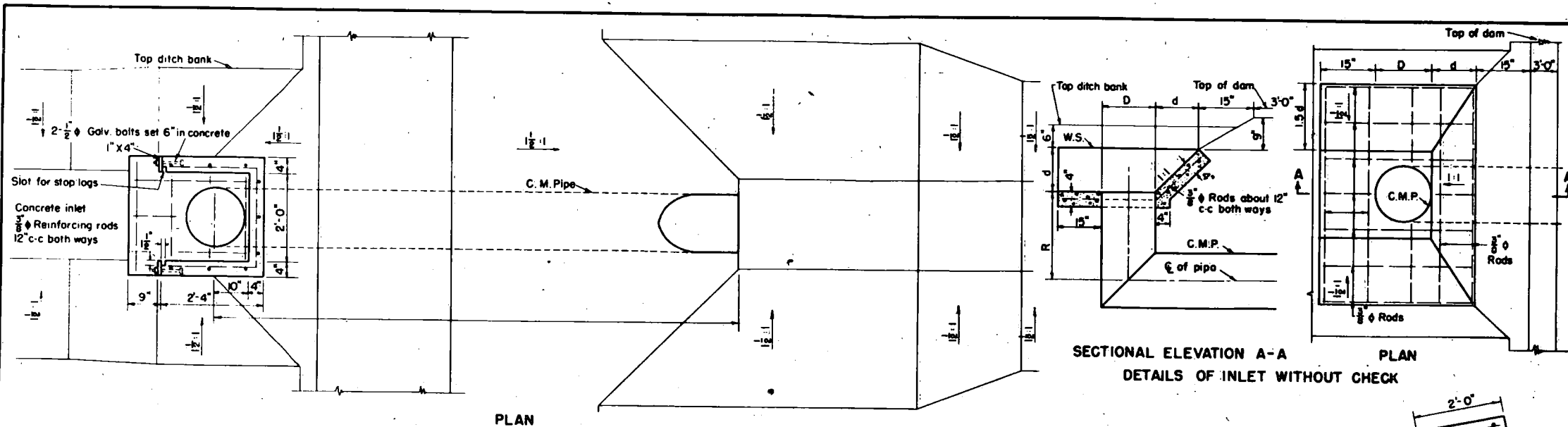

| H = R | D=10" | | | | D=12" | | | | D=15" | | | |
|-------|-------|-----|----------------|------------------|-------|------|----------------|------------------|-------|------|----------------|------------------|
| | V | Q | L _p | R+L _p | V | Q | L _p | R+L _p | V | Q | L _p | R+L _p |
| 1'-0" | 4.22 | 2.3 | 11'-0" | 12'-0" | 4.3 | 3.4 | 11'-0" | 12'-0" | 4.5 | 5.5 | 11'-0" | 12'-0" |
| 1'-6" | 5.14 | 2.8 | 10'-6" | 12'-0" | 5.2 | 4.1 | 10'-6" | 12'-0" | 5.4 | 6.6 | 12'-6" | 14'-0" |
| 2'-0" | 5.87 | 3.2 | 12'-0" | 14'-0" | 6.0 | 4.7 | 12'-0" | 14'-0" | 6.1 | 7.5 | 12'-0" | 14'-0" |
| 2'-6" | 6.42 | 3.5 | 13'-6" | 16'-0" | 6.6 | 5.2 | 13'-6" | 16'-0" | 6.8 | 8.4 | 13'-6" | 16'-0" |
| 3'-0" | 6.80 | 3.7 | 13'-0" | 16'-0" | 7.1 | 5.6* | 13'-0" | 16'-0" | 7.4 | 9.1* | 13'-0" | 16'-0" |

* Head required at pipe inlet (d) = 15"

NOMENCLATURE
 d - Depth of water in ditch
 D - Diameter of pipe
 R - Length of vertical pipe along center line
 L_p - Length of horizontal pipe along center line
 V - Velocity in pipe - f. s.
 Q - Discharge through pipe - c. f. s.
 H - Drop in water surface in canal
 H_e - Entrance head loss = $0.5 \frac{v^2}{g}$
 H_b - Loss of head at bend = $K \frac{v^2}{g}$
 H_f - Friction head loss in pipe = $\frac{2.87 n^2 v^2 (R + L_p)}{D^5}$
 H_v - Velocity head loss = $\frac{v^2}{2g}$
 Formula for discharge: $H = H_e + H_b + H_f + H_v, Q = eV$

NOTES

Select a pipe size that will provide a greater capacity than is required to discharge the normal head used when irrigating. Try to keep the velocity in the pipe below 3 f. s. based on normal irrigating head. When the velocity exceeds 3 f. s., particularly in sandy soil, a concrete outlet structure is required to eliminate detrimental erosion in the channel.

Reduce R + L_p by 2'-0" when using outlet structure.

The discharge capacities listed in the table are based on a 12" water depth above the top of the riser pipe except for 12" and 15" diameter pipes operating under 3'-0" H, which are based on a water depth of 15" above the top of the riser pipe.

The drop structure is formed by cutting a standard length corrugated metal pipe, which is manufactured in multiples of 2 ft in length, on a 45° angle and welding cut joints together to form a 90° bend. Pipe to be 16 ga. corrugated metal conforming to Federal Specifications Q-Q-806. Joint between horizontal and vertical pieces of pipe to be butt-welded and water-tight. Pipe to be thoroughly cleaned both inside and outside after welding and the entire pipe drop submerged in a bath of asphalt of approximately 45 penetration heated within a temperature range of from 250° F to 350° F. Pipe shall then be drained in a vertical position to remove excess asphalt as pipe cools. Other methods of applying asphalt coating will be considered.

When the corrugated metal pipe drop is used at a ditch crossing, increase width of top of dam and dimension L_p by 8'-0".

The drop (H) for any specific structure can be increased 3 inches by placing the top of the riser pipe 3 inches below the top of the concrete floor of the inlet. The thickness of the floor slab adjacent to the pipe should be increased 3 inches to make a watertight connection with the pipe. The inlet to the pipe should be rounded to a 3" radius to save forming and improve the efficiency of the inlet.

| | | | |
|---------------------------------------------------------------------------------------------|----------|---------------------|--------|
| CORRUGATED METAL DROP d=12" | | | |
| U. S. DEPARTMENT OF AGRICULTURE SOIL CONSERVATION SERVICE H. H. Bennett, Chief | | | |
| SECTION FIVE | | LINCOLN, NEBRASKA | |
| REFERENCE | | | |
| CARTOGRAPHIC APPROVAL | | ENGINEER'S APPROVAL | |
| COMPILED | TRACED | CHECKED | DATE |
| W. R. E. | R. H. B. | W. R. E. | 5-2-47 |
| | | DRAWING NO. | |
| | | S. R. 10,000.05 | |

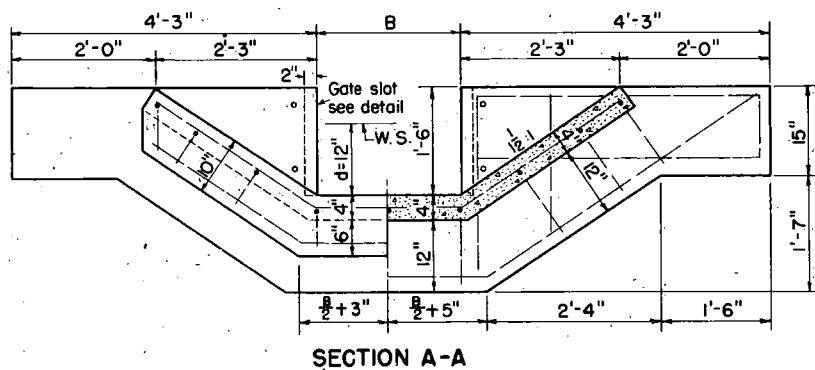
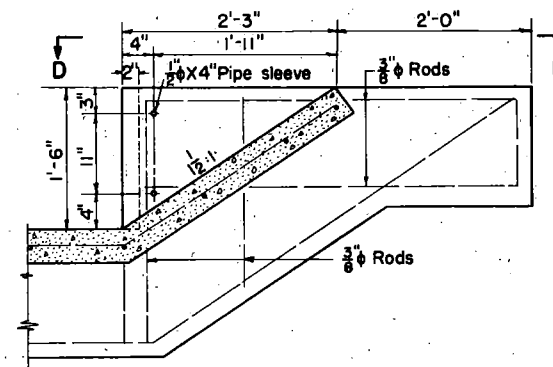
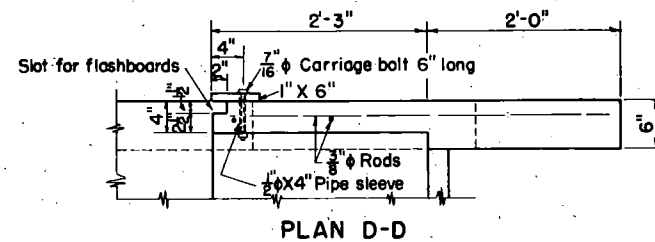
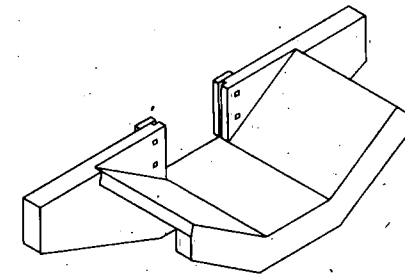
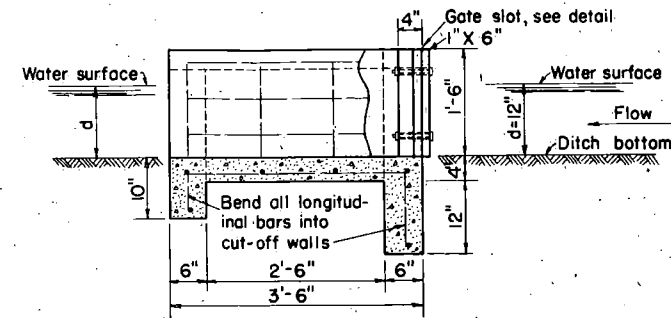
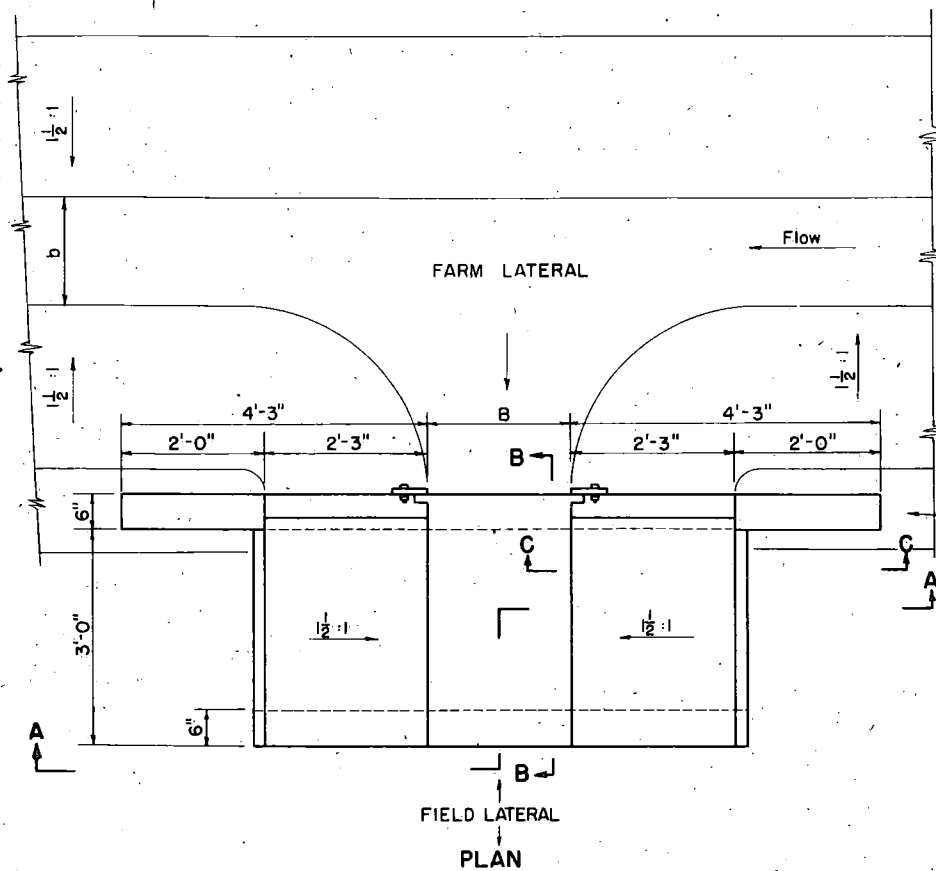

SECTION C-C
DETAILS OF CHECK AND GATE SLOT

| ITEM | UNIT | QUANTITIES | |
|---------------------------------------------|--------|------------|-------|
| | | B=18" | B=24" |
| Concrete | C. ft. | 17.4 | 18.3 |
| Reinforcing steel $\frac{3}{8}$ " ϕ | L. ft. | 113 | 116 |
| Lumber | B. F. | 2.5 | 4.5 |
| Pipe $\frac{1}{2}$ " ϕ 4" long-galv. | Each | 4 | 4 |
| Bolts $\frac{7}{16}$ " ϕ 6" long-galv. | Each | 4 | 4 |
| Washers 1" ϕ - galv. | Each | 4 | 4 |

NOTES

- B = Bottom width of turnout structure
- b = Bottom width of ditch
- d = Depth of water in ditch
- Reinforcing steel to be $\frac{3}{8}$ " diameter deformed rods spaced approximately 12" on center both ways placed near center of section. Bend longitudinal rods into cut-off walls as shown in Section B-B.
- Reinforcing steel to be intermediate grade
- Wire mesh may be substituted if equivalent cross sectional areas are provided.
- Use this structure or structures in combination with concrete check, Drawing No. 5,R-10,000.07 in place of division box. Locate structures so there is no physical connection between them.

| CONCRETE TURNOUT | | | |
|--------------------------------------------------------------|--------|--------------------|----------------------|
| d=12" | | | |
| U. S. DEPARTMENT OF AGRICULTURE SOIL CONSERVATION SERVICE | | | |
| H. H. Bennett, Chief | | | |
| REGION FIVE NEBRASKA | | LINCOLN, NEBRASKA | |
| CARTOGRAPHIC APPROVAL | | TECHNICAL APPROVAL | |
| COMPILED | | CHECKED | |
| TRACED | | DRAWN | |
| CORRECTED | | DRAWING NO. | |
| W.R.E. | R.H.B. | W.R.E. | 5-20-47 5R-10,000.06 |

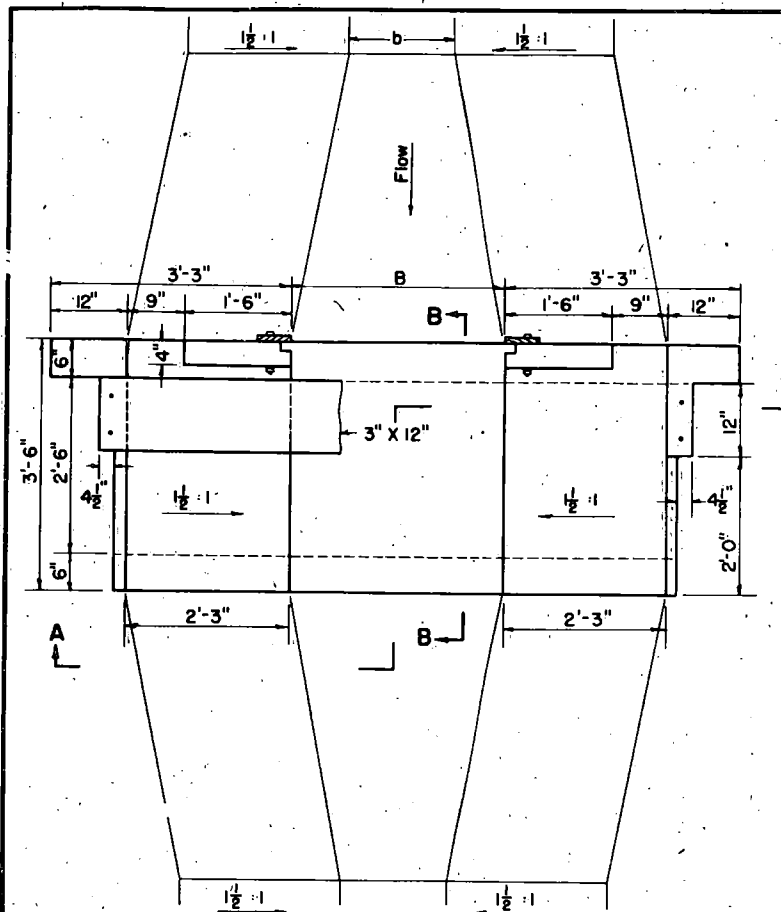

PLAN

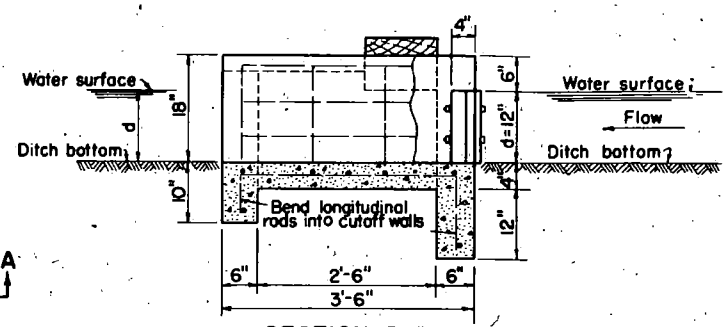

SECTION B-B

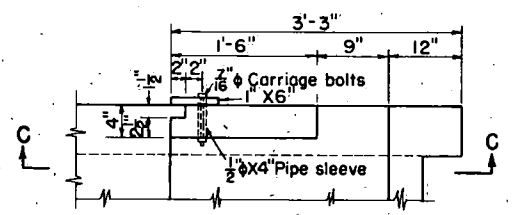

PLAN

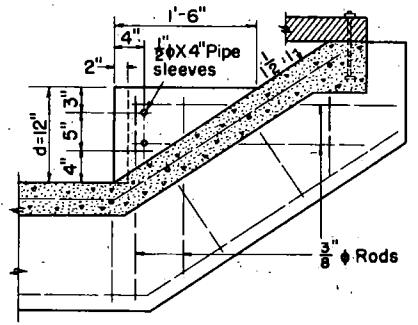

SECTION C-C
DETAILS OF CHECK AND GATE SLOT

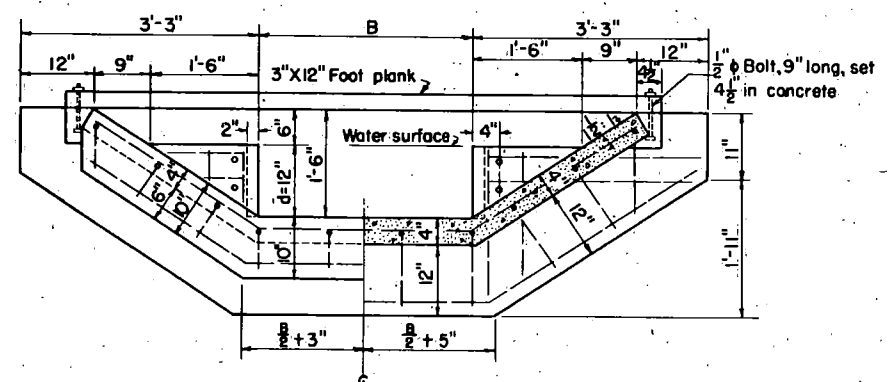

SECTION A-A

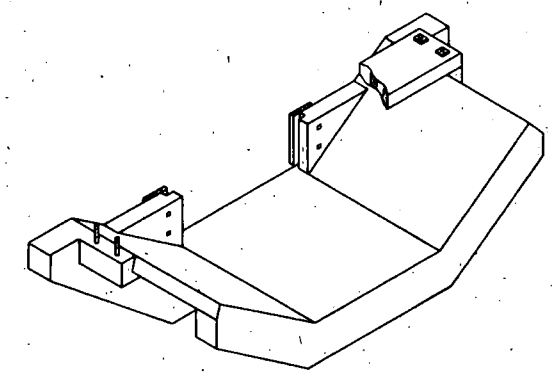

| ITEM | UNIT | QUANTITY | | | |
|-----------------------------|--------|----------|---------|---------|---------|
| | | B=2'-0" | B=2'-6" | B=3'-0" | B=3'-6" |
| Concrete | C. ft. | 17.2 | 18.1 | 19.0 | 20.0 |
| Reinforcing steel 3/8" | L. ft. | 105 | 112 | 115 | 123 |
| Lumber | B. F. | 28 | 28 | 35 | 35 |
| Pipe 1/2" x 4" long-galv. | Each | 4 | 4 | 4 | 4 |
| Bolts 7/16" x 6" long-galv. | Each | 4 | 4 | 4 | 4 |
| Bolts 1/2" x 9" long-galv. | Each | 4 | 4 | 4 | 4 |
| Washers 1" x galv. | Each | 8 | 8 | 8 | 8 |

NOTES

- B = Bottom width of check structure = $b + 1.5 d$
- b = Bottom width of ditch
- d = Depth of water in ditch
- Reinforcing steel to be 3/8" diameter deformed rods spaced approximately 12" on center both ways placed near center of section. Longitudinal rods to be bent into cut-off walls.
- Reinforcing steel to be intermediate grade
- Wire mesh may be substituted if equivalent cross-sectional areas are provided

CONCRETE CHECK
d = 12"

U. S. DEPARTMENT OF AGRICULTURE
SOIL CONSERVATION SERVICE
H. H. Bennett, Chief

REGION FIVE
REFERENCE

| CARTOGRAPHIC APPROVAL | | | TECHNICAL APPROVAL | |
|-----------------------|--------|---------|--------------------|--------------|
| COMPILED | TRACED | CHECKED | DATE | DRAWING NO. |
| W.R.E. | R.H.B. | W.R.E. | 5-20-47 | 5R-10,000.07 |

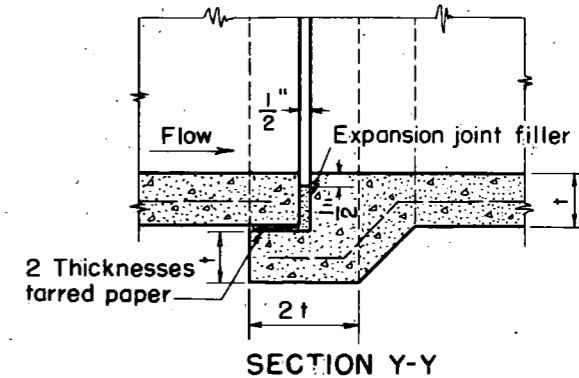
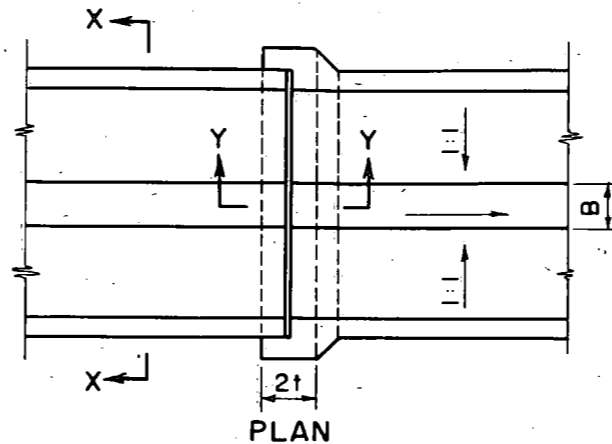
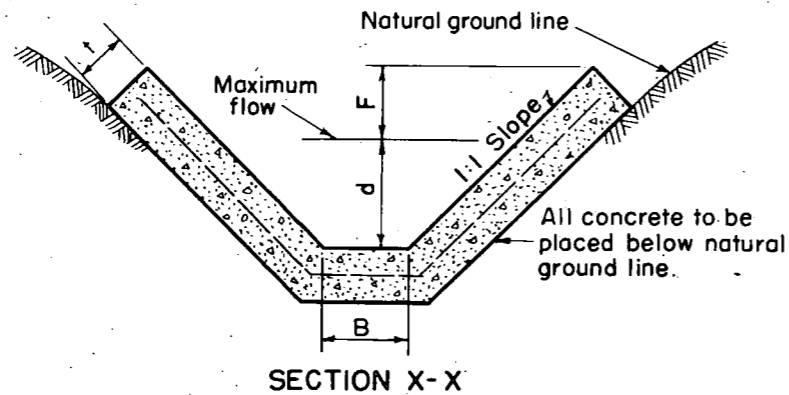

NOTES

Recommended Specifications

Reinforce section with welded wire fabric mesh, 12 gauge minimum, spaced at 4" each way. Weight of mesh - 19 lbs. per 100 square feet. Place mesh in center of section. Lap a minimum of 45 diameters at splices - 5" for 12 gauge.

Place expansion joints on 40' centers. Provide an expansion joint at juncture with structures. Make dummy joints 8' on centers by cutting with a trowel or mason's sidewalk jointer. Dummy joint should not exceed 3/4" in depth.

Concrete to have 3000 lbs. per square inch compressive strength at 28 days. Maximum water-cement ratio = 6.0 gallons per sack of cement. Slump range 1 to 3 inches. Maximum size aggregate - 3/4".

Keep lining wet for 5 days after pouring or spray with an asphaltic coating which is manufactured for this purpose.

Permissible Specifications

Pour lining continuously without expansion joints except at juncture with structures. Provide construction joints or dummy joints on 8' centers to control cracking. Construct without reinforcing. Concrete and curing specifications same as above.

- B = Base width of lined section
- d = Depth of water in ditch.
- S = Slope of water surface
- F = Freeboard, 4" minimum
- t = Thickness, 3" minimum

| LINED DITCH SELECTION CHART | | | | | | | | | | | | |
|-----------------------------|---------------|-----|-----|-----|-----|-----|-----|-----|-----|-----|-----|-----|
| S % | FLOW - C.F.S. | | | | | | | | | | | |
| | .5 | 1.0 | 1.5 | 2.0 | 2.5 | 3.0 | 3.5 | 4.0 | 4.5 | 5.0 | 5.5 | 6.0 |
| 1 | A | B | D | E | F | G | G | G | G | G | H | H |
| 2 | A | A | B | E | D | E | F | F | G | G | G | G |
| 3 | A | A | A | C | D | D | E | E | F | F | G | G |
| 4 | A | A | A | B | C | D | D | E | E | F | F | G |
| 5 | A | A | A | B | C | C | D | D | E | E | F | F |
| 6 | A | A | A | A | B | C | D | D | D | E | E | F |
| 7 | A | A | A | A | B | C | C | D | D | D | E | E |
| 8 | A | A | A | A | B | B | C | D | D | D | D | E |
| 9 | A | A | A | A | A | B | C | C | D | D | D | E |
| 10 | A | A | A | A | A | B | C | C | D | D | D | D |
| 11 | A | A | A | A | A | B | B | C | C | D | D | D |
| 12 | A | A | A | A | A | B | B | C | C | D | D | D |

| TABLE OF QUANTITIES FOR 100 LINEAL FEET CONCRETE LINED DITCH | | | | |
|--------------------------------------------------------------------|------------|-----|---------------------|-----------------|
| Section | Dimensions | | Concrete Cu. Ft. | Mesh Sq. Ft. |
| | b | d+F | | |
| A | 5" | 8" | 62.4 | 233 |
| B | 7 | 8 | 66.6 | 250 |
| C | 9 | 8 | 70.6 | 267 |
| D | 5 | 10 | 74.4 | 283 |
| E | 7 | 10 | 78.5 | 300 |
| F | 9 | 10 | 82.6 | 317 |
| G | 9 | 12 | 94.7 | 367 |
| H | 12 | 12 | 100.9 | 392 |

| | | | | |
|----------------------------------------------------------------------|--------|-------------------|--------------------|---------------|
| CONCRETE LINED DITCH SECTION | | | | |
| U. S. DEPARTMENT OF AGRICULTURE SOIL CONSERVATION SERVICE | | | | |
| H. H. Bennett, Chief | | | | |
| REGION FIVE | | LINCOLN, NEBRASKA | | |
| REFERENCE | | | | |
| CARTOGRAPHIC APPROVAL | | | TECHNICAL APPROVAL | |
| | | | <i>[Signature]</i> | |
| COMPILED | TRACED | CHECKED | DATE | DRAWING NO. |
| | R.H.B. | C.J.F. | 11-13-47 | 5,R-10,000.15 |

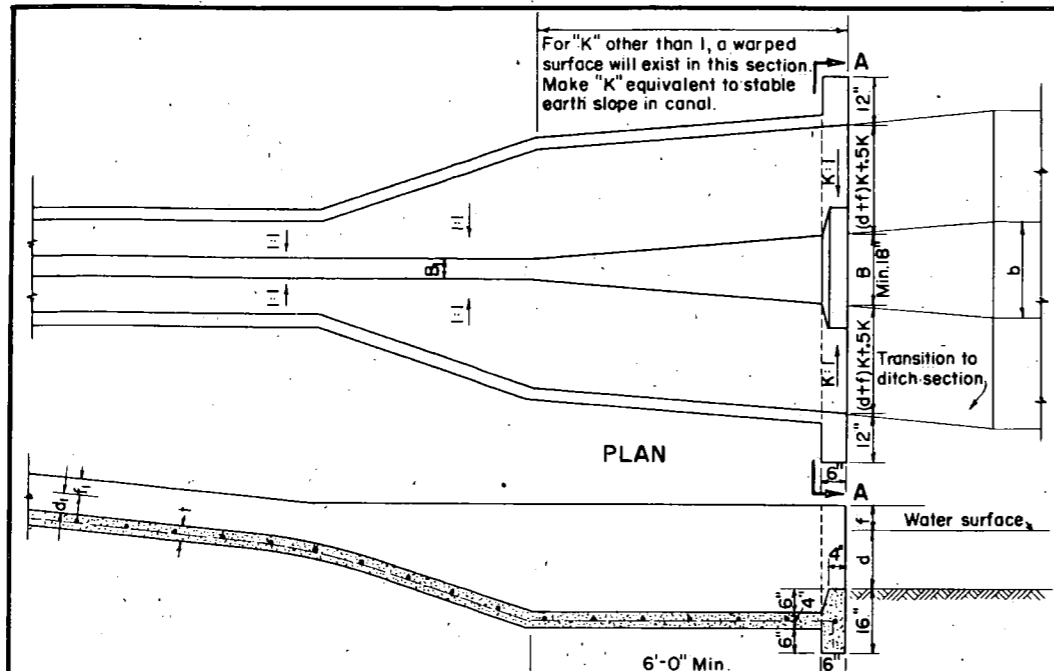

For "K" other than 1, a warped surface will exist in this section. Make "K" equivalent to stable earth slope in canal.

PLAN

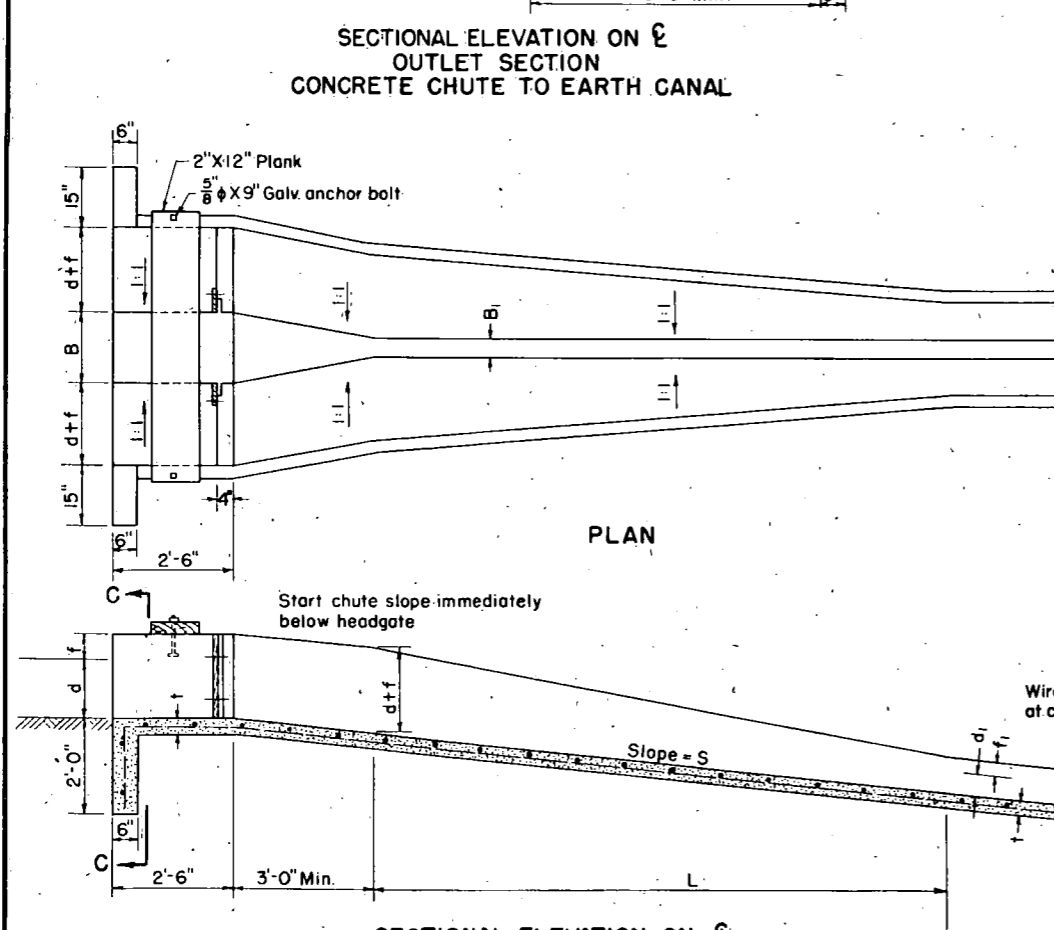

SECTIONAL ELEVATION ON C-C
OUTLET SECTION
CONCRETE CHUTE TO EARTH CANAL

PLAN

SECTIONAL ELEVATION ON C-C
INLET SECTION
EARTH CANAL TO CONCRETE CHUTE

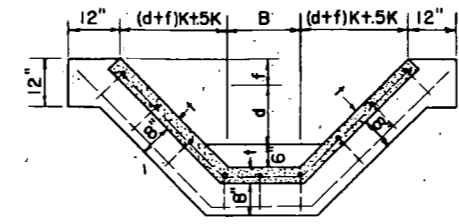

SECTION A-A

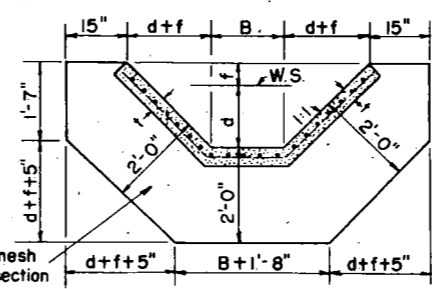

SECTION C-C

INLET AND OUTLET

RECOMMENDED SPECIFICATIONS
 Reinforce with welded wire fabric mesh, 12 gauge minimum, spaced at 4" each way. Weight of mesh - 19 lbs. per 100 square feet. Place mesh in center of section. Lap a minimum of 45 diameters at splices - 5" for 12 gauge.
 Provide dummy joints B' on centers by cutting with a trowel or mason's sidewalk jointer. Dummy joint should not exceed 3/4" in depth.
 Concrete to have 3000 lbs. per square inch compressive strength at 28 days. Maximum water-cement ratio = 6.0 gallons per sack of cement. Slump range 1 to 3 inches. Maximum size aggregate - 3/4".
 Keep lining wet for 5 days after pouring or spray with an asphaltic coating which is manufactured for this purpose.

HILLSIDE TURNOUTS

Reinforcement in structure to be 3/8" bars placed in center of slabs and spaced 12" c - c both ways. All longitudinal bars to be bent into cutoffs. Wire mesh may be substituted if equivalent cross-sectional area is provided. Refer to Drawing No. 5, R-10,000.15 for specifications on reinforcing the chute section. Lap bars 15" at splices.
 Keep concrete wet for 5 days after pouring or spray with an asphaltic coating which is manufactured for this purpose.

INLET AND OUTLET

PERMISSIBLE SPECIFICATIONS
 Pour lining continuously without expansion joints except at juncture with structures. Provide construction joints or dummy joints on 8' centers to control cracking. Construct without reinforcing. Concrete and curing specifications same as above.

NOMENCLATURE

- B = Base width of chute entrance or turnouts
- B₁ = Base width of chute
- b = Base width of earth ditch
- d = Depth of water in ditch
- d₁ = Depth of water in chute
- f = Freeboard at chute entrance, outlet or at turnout - Min. 6"
- f₁ = Freeboard in chute section - Min. 4"
- K = Side slope factor
- L = Length of transition
- S = Slope of chute
- Q = Discharge in cu. ft. per sec.
- t = Thickness of concrete lining - Min. thickness 3"

All lining to be placed on undisturbed natural earth or thoroughly compacted backfill.

LENGTH OF TRANSITION REQUIRED AT INLET OF CHUTE FOR VARYING DISCHARGES AND SLOPES

| Slope % | Q=3.0 C.F.S. | Q=4.0 C.F.S. | Q=5.0 C.F.S. | | | |
|---------|-----------------------------------|----------------------------------------|-----------------------------------|----------------------------------------|----------|----------------------------------------|
| | d=1.1', B=12", B ₁ =5" | d=1.0', B=18", B ₁ =5" | d=1.2', B=18", B ₁ =5" | | | |
| | (L) feet | d ₁ + f ₁ inches | (L) feet | d ₁ + f ₁ inches | (L) feet | d ₁ + f ₁ inches |
| 6 | 10 | 9 | 15 | 10 | 19 | 10 |
| 8 | 9 | 9 | 14 | 10 | 18 | 10 |
| 10 | 8 | 9 | 13 | 9 | 17 | 10 |
| 12 | 7 | 8 | 11 | 9 | 15 | 9 |
| 15 | 6 | 8 | 9 | 9 | 13 | 9 |

INLET, OUTLET & TURNOUT STRUCTURES FOR CONCRETE CHUTE

U. S. DEPARTMENT OF AGRICULTURE
 SOIL CONSERVATION SERVICE

H. H. Bennett, Chief

REGION FIVE LINCOLN, NEBRASKA

REFERENCE

| | | | |
|----------------------------------|--------------------|-------------------------------|-----------------|
| CARTOGRAPHIC APPROVAL | | TECHNICAL APPROVAL | |
| COMPILED C. J. F. W. R. E. | TRACED R. H. B. | CHECKED C. J. F. | DATE 2-19-48 |
| | | DRAWING NO. 5, R-10,000.19 | |

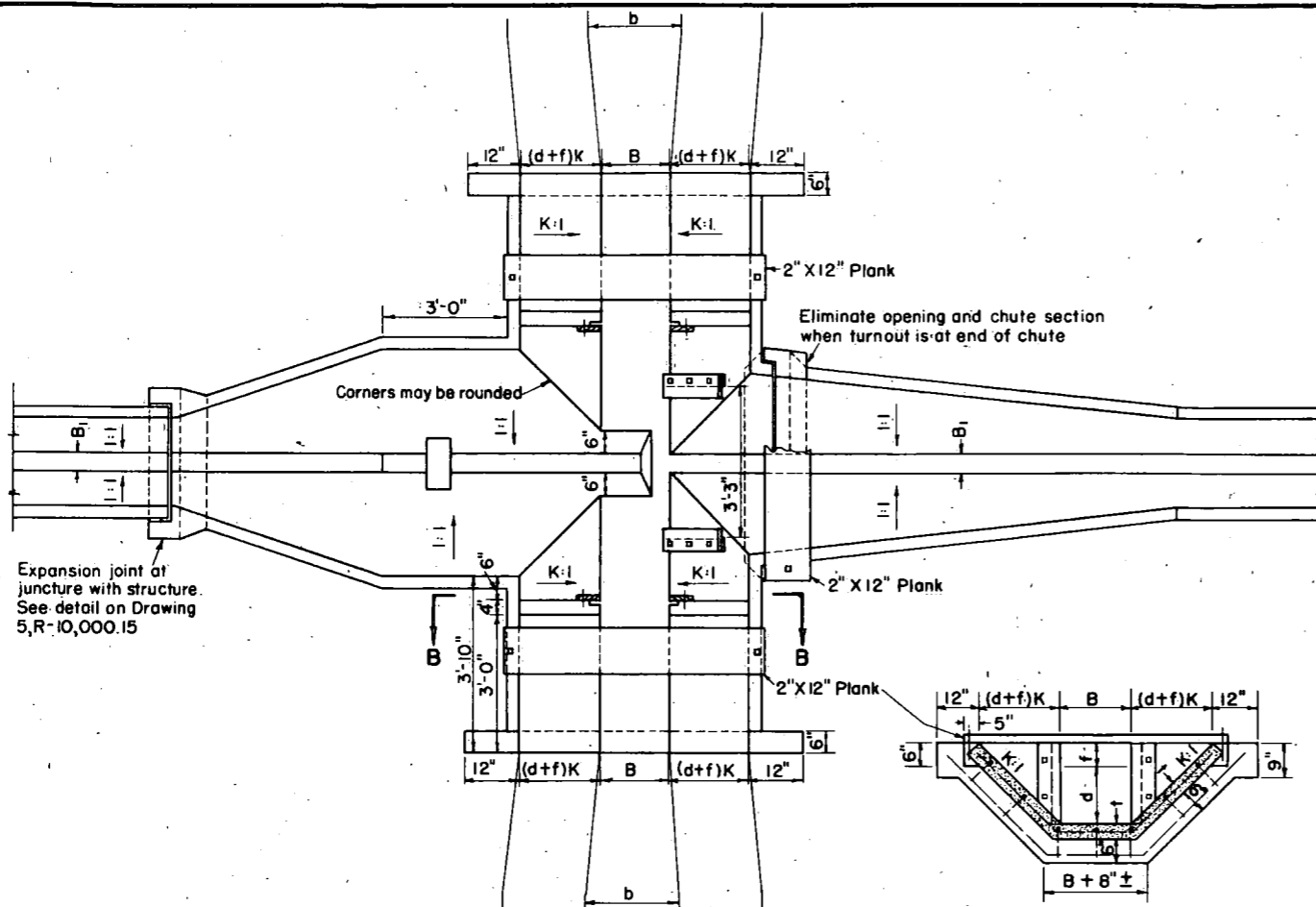

PLAN
TWO-WAY HILLSIDE TURNOUT

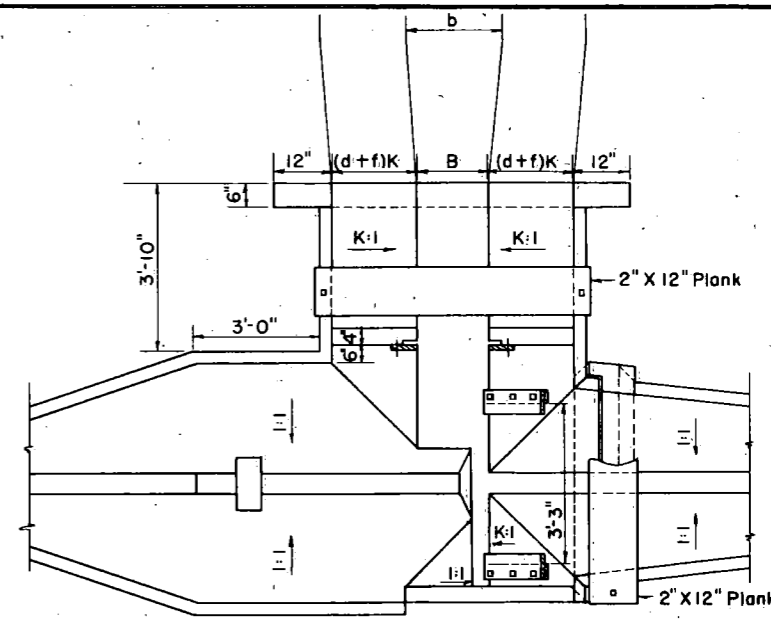

PLAN
ONE-WAY HILLSIDE TURNOUT
CONTINUOUS CHUTE

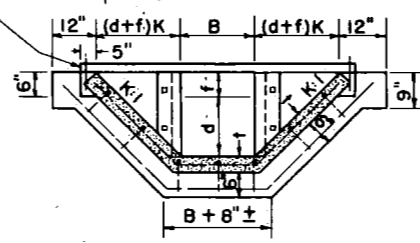

SECTION B-B

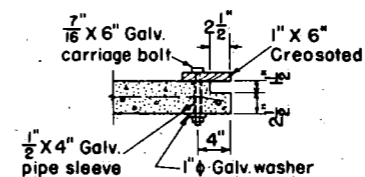

DETAIL OF GATE SLOT

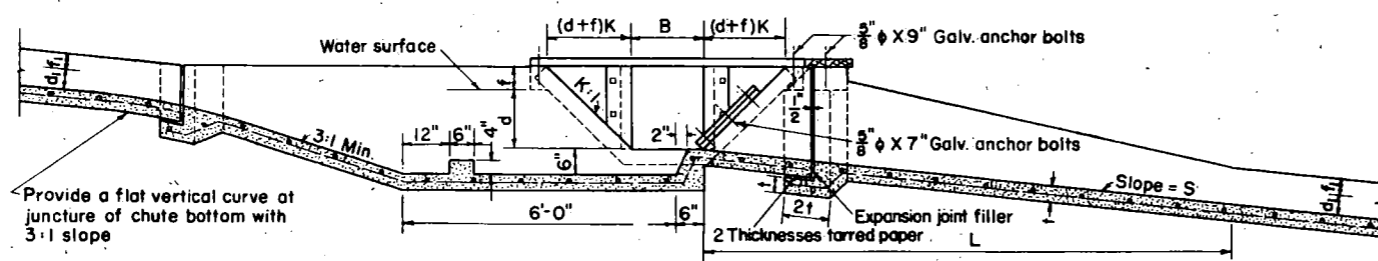

SECTIONAL ELEVATION ON C/L
TWO WAY HILLSIDE TURNOUT
CONTINUOUS CHUTE

LENGTH OF TRANSITION BELOW HILLSIDE TURNOUT
FOR VARYING DISCHARGES AND SLOPES

| Slope % | Q=3.0 C.F.S. B ₁ =5", d=1.0' | | Q=4.0 C.F.S. B ₁ =5", d=1.1' | | Q=5.0 C.F.S. B ₁ =5", d=1.2' | |
|---------|--------------------------------------------|---------------------------------------|--------------------------------------------|---------------------------------------|--------------------------------------------|---------------------------------------|
| | (L) feet | d ₁ +f ₁ inches | (L) feet | d ₁ +f ₁ inches | (L) feet | d ₁ +f ₁ inches |
| 6 | 13 | 9 | 18 | 10 | 22 | 10 |
| 8 | 12 | 9 | 17 | 10 | 21 | 10 |
| 10 | 11 | 9 | 16 | 9 | 20 | 10 |
| 12 | 10 | 8 | 14 | 9 | 18 | 9 |
| 15 | 9 | 8 | 12 | 9 | 16 | 9 |

**INLET, OUTLET & TURNOUT
STRUCTURES FOR CONCRETE CHUTE**

U. S. DEPARTMENT OF AGRICULTURE
SOIL CONSERVATION SERVICE
H. H. Bennett, Chief LINCOLN, NEBRASKA

REGION FIVE REFERENCE

| | | | |
|-----------------------|------------------|------------------------------|-----------------|
| CARTOGRAPHIC APPROVAL | | TECHNICAL APPROVAL | |
| COMPILED G.W.E. | TRACED R.H.B. | CHECKED C.J.F. | DATE 2-19-48 |
| | | DRAWING NO. 5,R-10,000.19 | |

PRELIMINARY COST ESTIMATE

No precise estimate of cost is possible without detailed information which can be available only after construction surveys have been made. Also, standards of construction and types of structures would have to be determined definitely. However, for guidance of the District and of the water users in planning the development of the project, a preliminary cost estimate has been prepared.

This estimate is based on construction of the entire distribution and disposal systems as herein described. As indicated previously, it assumes a rather high standard of design and construction. If construction engineering and design is directed particularly to economy, savings should be effected within this estimate. If such design includes some sacrifice of "permanence", very considerable reduction in first cost from this estimate might be realized.

As a guide to the total costs that may be involved, a summary estimate has been prepared as follows:

Distribution System

| | | |
|-----------------|-----------|-----------------|
| Under High Line | \$ 21,500 | |
| Under Low Line | \$ 44,600 | |
| Sub-Total | \$ 66,100 | |
| Contingencies | \$ 6,900 | |
| Total | \$ 73,000 | ----- \$ 73,000 |

Water Disposal System

| | | |
|------------------------------------------------------|-----------|------------------|
| Estimated Total | \$ 24,200 | |
| Contingencies | \$ 2,800 | |
| Total | \$ 27,000 | ----- \$ 27,000 |
| Combined Total for Distribution and Disposal Systems | | ----- \$ 100,000 |
| Design and Construction Engineering | | ----- \$ 15,000 |
| Grand Total | | ----- \$ 115,000 |

For the total project of 7,268 acres this would be an average cost of about \$15.80 per acre.

AREAS TO BE SERVED

The approximate acreages of service upon which the plan is based have been estimated and are shown in Table II by ownerships and in Table III by main canal turnouts. These acreages can be only tentative and approximate. Actual irrigable areas have not been delineated. Furthermore, detailed project plans and farm plans will shift acreage from one source of service to another. Totals shown, however, are sufficiently precise to show the pattern of service contemplated and the total of the area to be served will probably prove to be quite close to the actual acreage that will be irrigated eventually.

TABLE II -Sheet 1 of 5-Estimated Acreages Served in Each
Ownership

| Owner No. | OTO No. | Acres | |
|--------------|------------|------------|---------------------------|
| 3 | 31 | 10 | |
| | 1 | 28 | |
| | 2 | 61 | |
| | 3 | 184 | |
| | 4 | 19 | |
| | 34 | <u>24</u> | Total, Owner #3 326 Acres |
| 4 | 2 | 29 | |
| | 32 | <u>11</u> | Total, Owner #4 40 " |
| 5 | 2 | 3 | (From Owner #4) |
| | 31a | 72 | |
| | 33 | <u>48</u> | Total, Owner #5 123 " |
| 6 | 4 | 96 | Total, Owner #6 96 " |
| 7 | 4a | 9 | |
| | 5 | 31 | |
| | 6 | 142 | |
| | 7 | 40 | |
| | 14 | 115 | |
| | 16 | 34 | |
| | 18 | 189 | |
| | 41 | 90 | |
| | 43 | 63 | |
| | 49 | <u>129</u> | Total, Owner #7 842 " |

TABLE II

-Sheet 2 of 5-

| Owner No. | OTO No. | Acres | |
|-----------|---------|------------|--------------------------|
| 9 | 4 | 37 | (30 ac. below lowline) |
| | 35 | <u>30</u> | Total, Owner #9 67 Acres |
| 10 | 9 | 3 | (From Owner #41) |
| | 7 | 51 | |
| | 14 | 378 | |
| | 42 | 15 | |
| | 40 | 53 | |
| | 39 | <u>30</u> | Total, Owner #10 530 " |
| 11 | 14 | 6 | (From Owner #10) |
| | 7 | 18 | |
| | 36 | 15 | |
| | 38 | 103 | |
| | 37 | <u>38</u> | Total, Owner #11 180 " |
| | 12 | 37 | 118 |
| 13 | 38 | 34 | |
| | 41 | <u>95</u> | Total, Owner #13 129 " |
| 14 | 41 | 15 | |
| | 43 | <u>100</u> | Total, Owner #14 115 " |
| 15 | 43 | 45 | |
| | 45 | 72 | |
| | 47 | 38 | |
| | 46 | <u>39</u> | Total, Owner #15 194 " |
| 16 | 43 | 27 | Total, Owner #16 27 " |
| 17 | 43 | 90 | |
| | 43 | 3 | (From Owner #14) |
| | 45 | <u>20</u> | Total, Owner #17 113 " |
| 18 | 43 | 85 | Total, Owner #18 85 " |
| 19 | 46 | 39 | |
| | 47 | 37 | |
| | 55 | 40 | |
| | 53 | <u>158</u> | Total, Owner #19 274 " |
| 20 | 47 | 7 | (From Owner #15) |
| | 47 | <u>40</u> | Total, Owner #20 47 " |
| 21 | 45 | 38 | |
| | 47 | <u>56</u> | Total, Owner #21 94 " |

TABLE II

-Sheet 3 of 5

| Owner No. | OTO No. | Acres | |
|-----------|---------|------------|---------------------------|
| 22 | 47 | 78 | Total, Owner #22 78 Acres |
| 23 | 51 | 38 | Total, Owner #23 38 " |
| 24 | 47 | 36 | Total, Owner #24 36 " |
| 25 | 47 | 46 | Total, Owner #25 78 " |
| | 51 | <u>32</u> | |
| 26 | 53 | 125 | Total, Owner #26 225 " |
| | 60 | <u>100</u> | |
| 27 | 51 | 50 | Total, Owner #27 73 " |
| | 53 | <u>23</u> | |
| 28 | 53 | 67 | Total, Owner #28 343 " |
| | 57 | 91 | |
| | 60 | <u>185</u> | |
| 29 | 60 | 130 | Total, Owner #29 130 " |
| 30 | 58 | 69 | Total, Owner #30 104 " |
| | 60 | <u>35</u> | |
| 31 | 59 | 15 | Total, Owner #31 15 " |
| 32 | 56 | 40 | Total, Owner #32 40 " |
| 33 | 51 | 15 | Total, Owner #33 81 " |
| | 52 | 20 | |
| | 54 | <u>46</u> | |
| 34 | 51 | 101 | Total, Owner #34 157 " |
| | 53 | <u>56</u> | |
| 35 | 19 | 18 | Total, Owner #35 28 " |
| | 50 | <u>10</u> | |
| 36 | 18 | 40 | Total, Owner #36 40 " |
| 37 | 18 | 112 | Total, Owner #37 159 " |
| | 19 | 3 | |
| | 48 | <u>44</u> | |
| 38 | 14 | 47 | Total, Owner #38 152 " |
| | 18 | 21 | |
| | 44 | 47 | |
| | 45 | <u>37</u> | |

TABLE II

-Sheet 4 of 5-

| Owner No. | OTO No. | Acres | | |
|-----------|---------|------------|------------------|----------|
| 39 | 46 | 66 | Total, Owner #39 | 78 Acres |
| | 18 | <u>12</u> | | |
| 40 | 18 | 79 | Total, Owner #40 | 79 " |
| 41 | 7 | 8 | Total, Owner #41 | 283 " |
| | 8 | 122 | | |
| | 9 | 140 | | |
| | 10 | <u>13</u> | | |
| 42 | 11 | 155 | Total, Owner #42 | 155 " |
| 43 | 12 | 16 | Total, Owner #43 | 112 " |
| | 14 | <u>96</u> | | |
| 44 | 13 | 10 | Total, Owner #44 | 96 " |
| | 15 | 56 | | |
| | 16 | <u>30</u> | | |
| 45 | 17 | 16 | Total, Owner #45 | 16 " |
| 46 | 60 | 15 | (From Owner #29) | |
| | 60 | 5 | | |
| | 61 | 135 | | |
| | 69 | 10 | | |
| | 70 | 70 | | |
| | 71 | <u>100</u> | Total, Owner #46 | 335 " |
| 47 | 72 | 162 | Total, Owner #47 | 214 " |
| | 73 | <u>52</u> | | |
| 48 | 74 | 70 | Total, Owner #48 | 70 " |
| 49 | 73 | 40 | Total, Owner #49 | 185 " |
| | 75 | <u>145</u> | | |
| 51 | 71 | 11 | Total, Owner #51 | 11 " |
| 52 | 61 | 8 | (From Owner #46) | |
| | 62 | 30 | | |
| | 69 | <u>140</u> | Total, Owner #52 | 178 " |
| 53 | 63 | 50 | Total, Owner #53 | 190 " |
| | 64 | 20 | | |
| | 67 | 40 | | |
| | 68 | <u>80</u> | | |

TABLE II

-Sheet 5 of 5-

| Owner No. | OTO No. | Acres | | |
|-----------|---------|-----------|------------------|----------|
| 54 | 64 | 15 | | |
| | 65 | 20 | | |
| | 66 | <u>13</u> | Total, Owner #54 | 48 Acres |
| 55 | 73 | 20 | Total, Owner #55 | 20 " |

TOTAL Estimated Area Served: 7,247 Acres.

* * * * *

TABLE III

-Sheet 1 of 5-

Estimated Acreages Served from each Main Canal Turnout

| Main Canal : Approximate : | Turnout No. : Canal Station : | Laterals Supplied : | Ownership : | Acres |
|----------------------------|-------------------------------|---------------------|-----------------|--------------|
| Under Highline Canal : | | | | |
| 1 | : 103 + 40 | : None | : 3 (Total) | 28 |
| 2 | : 133 + 00 | : CL2-1 | : 3 | : 61 |
| | | | : 4 | : 29 |
| | | | : 5 | : <u>3</u> |
| | | | : (Total) | 93 |
| 3 | : 163 + 10 | : None | : 3 (Total) | 184 |
| 4 | : 173 + 40 | : L4-1.0 & CL4-1.1 | : 3 | : 19 |
| | | | : 6 | : 96 |
| | | | : 9 | : <u>37</u> |
| | | | : (Total) | 152 |
| 4a | : 179 + 00 | : None | : 7 (Total) | 9 |
| 5 | : 190 + 70 | : None | : 7 (Total) | 31 |
| 6 | : 203 + 80 | : None | : 7 (Total) | 142 |
| 7 | : 210 + 10 | : L7-1.0 & L7-1.1 | : 7 | : 40 |
| | | | : 10 | : 51 |
| | | | : 11 | : 18 |
| | | | : 41 | : <u>8</u> |
| | | | : (Total) | 117 |
| 8 | : 223 + 00 | : None | : 41 (Total) | 122 |
| 9 | : 246 + 00 | : None | : 10 (thru #41) | : 3 |
| | | | : 41 | : <u>140</u> |
| | | | : (Total) | 143 |

TABLE III -Sheet 2 of 5-
 Estimated Acreages Served from each Main Canal Turnout

| Main Canal : Approximate : | | | | | |
|----------------------------|----------------|--------------------|--------------|---------|-----|
| Turnout No. : | Canal Station: | Laterals Supplied: | Ownership : | Acres | |
| Under Highline Canal : | | | | | |
| 10 | 270 + 00 | None | 41 | (Total) | 13 |
| 11 | 283 + 70 | None | 42 | (Total) | 155 |
| 12 | 299 + 80 | None | 43 | (Total) | 16 |
| 13 | 313 + 10 | None | 44 | (Total) | 10 |
| 14 | 321 + 40 | L14-1.0 & L14-1.1: | 7 | | 115 |
| | | | 10 | | 378 |
| | | | 38 | | 47 |
| | | | 11 | | 6 |
| | | | 43 | | 96 |
| | | | | (Total) | 642 |
| 15 | 322 + 00 | None | 44 | (Total) | 56 |
| 16 | 342 + 40 | CL16-1 | 7 | | 34 |
| | | | 44 | | 30 |
| | | | | (Total) | 64 |
| 17 | 372 + 60 | None | 45 | (Total) | 16 |
| 18 | 387 + 20 | L18-1.0 & L18-1.1: | 7 | | 189 |
| | | | 36 | | 40 |
| | | | 37 | | 112 |
| | | | 38 | | 21 |
| | | | 39 | | 12 |
| | | | 40 | | 79 |
| | | | | (Total) | 453 |
| 19 | 424 + 20 | None | 35 | | 18 |
| | | | 37(thru 35): | | 3 |
| | | | | (Total) | 21 |

TOTAL from 20 OTO's from Highline Canal: 2,467 Acres

| Main Canal : Approximate : | | | | | |
|----------------------------|----------------|--------------------|-------------|---------|----|
| Turnout No. : | Canal Station: | Laterals Supplied: | Ownership : | Acres | |
| Under Lowline Canal : | | | | | |
| 31 | 95 + 00 | None | 3 | (Total) | 10 |
| 31a | 114 + 00 | None | 5 | (Total) | 72 |

TABLE III

-Sheet 3 of 5-

| Main Canal : Approximate : | | | | | |
|----------------------------|-----------------|----------------------|-------------|---------|------------|
| Turnout No. : | Canal Station : | Laterals Supplied : | Ownership : | Acres | |
| Under Lowline Canal : | | | | | |
| 32 | : 115 + 40 | : None | : 4 | (Total) | 11 |
| 33 | : 137 + 50 | : None | : 5 | (Total) | 48 |
| 34 | : 152 + 10 | : None | : 3 | (Total) | 24 |
| 35 | : 202 + 50 | : None | : 9 | (Total) | 30 |
| 36 | : 247 + 10 | : None | : 11 | (Total) | 15 |
| 37 | : 259 + 20 | : CL37-1 | : 11 | : | 38 |
| | | | : 12 | : | <u>118</u> |
| | | | | (Total) | 156 |
| 38 | : 289 + 10 | : CL38-1 | : 11 | : | 103 |
| | | | : 13 | : | <u>34</u> |
| | | | | (Total) | 137 |
| 39 | : 289 + 40 | : None | : 10 | (Total) | 30 |
| 40 | : 313 + 70 | : None | : 10 | (Total) | 53 |
| 41 | : 326 + 40 | : L41-1.0 & CL41-1.1 | : 7 | : | 90 |
| | | | : 13 | : | 95 |
| | | | : 14 | : | <u>15</u> |
| | | | | (Total) | 200 |
| 42 | : 337 + 60 | : None | : 10 | (Total) | 15 |
| 43 | : 353 + 30 | : L43-1 | : 7 | : | 63 |
| | | | : 14 | : | 100 |
| | | | : 15 | : | 45 |
| | | | : 16 | : | 27 |
| | | | : 17 | : | 93 |
| | | | : 18 | : | <u>85</u> |
| | | | | (Total) | 413 |
| 44 | : 354 + 15 | : None | : 38 | (Total) | 47 |
| 45 | : 373 + 80 | : L45-1 | : 15 | : | 72 |
| | | | : 17 | : | 20 |
| | | | : 21 | : | 38 |
| | | | : 38 | : | <u>37</u> |
| | | | | (Total) | 167 |

TABLE III

-Sheet 4 of 5-

| Main Canal : Approximate : | | | | | |
|----------------------------|----------------|-------------------------------------|-------------|---------|------------|
| Turnout No. : | Canal Station: | Laterals Supplied: | Ownership : | Acres | |
| Under Lowline Canal : | | | | | |
| 46 | 382 + 50 | L46-1 | 15 | | 39 |
| | | | 19 | | 39 |
| | | | 39 | | <u>66</u> |
| | | | | (Total) | 144 |
| 47 | 408 + 55 | L47-1.0, L47-1.1 L47-1.2&L47-1.3 | 15 | | 38 |
| | | | 19 | | 37 |
| | | | 20 | | 47 |
| | | | 21 | | 56 |
| | | | 22 | | 78 |
| | | | 24 | | 36 |
| | | | 25 | | <u>46</u> |
| | | | | (Total) | 338 |
| 48 | 415 + 10 | None | 37 | (Total) | 44 |
| 49 | 427 + 80 | None | 7 | (Total) | 129 |
| 50 | 447 + 30 | None | 35 | (Total) | 10 |
| 51 | 459 | L51-1.0 & L51-1.1 | 23 | | 38 |
| | | | 25 | | 32 |
| | | | 27 | | 50 |
| | | | 33 | | 15 |
| | | | 34 | | <u>101</u> |
| | | | | (Total) | 236 |
| 52 | 477 + 00 | None | 33 | (Total) | 20 |
| 53 | 486 + 60 | L53-1.0 & L53-1.1 | 19 | | 158 |
| | | | 26 | | 125 |
| | | | 27 | | 23 |
| | | | 28 | | 67 |
| | | | 34 | | <u>56</u> |
| | | | | (Total) | 429 |
| 54 | 490 + 40 | None | 33 | (Total) | 46 |
| 55 | 508 + 30 | None | 19 | (Total) | 40 |
| 56 | 529 + 70 | None | 32 | (Total) | 40 |
| 57 | 549 + 00 | L57-1 | 28 | (Total) | 91 |
| 58 | 564 + 40 | None | 30 | (Total) | 69 |
| 59 | 595 + 00 | None | 31 | (Total) | 15 |

TABLE III -Sheet 5 of 5

| Main Canal : Approximate : | | | | | |
|-----------------------------------------------|----------------|--------------------|--------------|---------|-----|
| Turnout No. : | Canal Station: | Laterals Supplied: | Ownership : | Acres | |
| Under Lowline Canal : | | | | | |
| 60 | 600 + 90 | L60-1.0 & L60-1.1: | 26 | : | 100 |
| | | | 28 | : | 185 |
| | | | 29 | : | 130 |
| | | | 30 | : | 35 |
| | | | 46 | : | 20 |
| | | | | (Total) | 470 |
| 61 | 635 + 20 | None | 46 | : | 135 |
| | | | 52(thru 46): | : | 8 |
| | | | | (Total) | 143 |
| 62 | 677 + 10 | None | 52 | (Total) | 30 |
| 63 | 701 + 10 | None | 53 | (Total) | 50 |
| 64 | 717 + 10 | None | 53 | : | 20 |
| | | | 54(thru 53): | : | 15 |
| | | | | (Total) | 35 |
| 65 | 742 + 20 | None | 54 | (Total) | 20 |
| 66 | 752 + 80 | None | 54 | (Total) | 13 |
| 67 | 768 + 50 | None | 53 | (Total) | 40 |
| 68 | 807 + 50 | L68-1 | 53 | (Total) | 80 |
| 69 | 836 + 50 | None | 52 | : | 140 |
| | | | 46(thru 52): | : | 10 |
| | | | | (Total) | 150 |
| 70 | 853 + 80 | None | 46 | (Total) | 70 |
| 71 | 874 + 30 | L71-1.0 | 46 | : | 100 |
| | | | 51 | : | 11 |
| | | | | (Total) | 111 |
| 72 | 889 + 50 | None | 47 | (Total) | 162 |
| 73 | 920 + 60 | L73-1.0 & L73-1.1: | 47 | : | 52 |
| | | | 49 | : | 40 |
| | | | 55 | : | 20 |
| | | | | (Total) | 112 |
| 74 | 937 + 70 | None | 48 | (Total) | 70 |
| 75 | 977 + 80 | None | 49 | (Total) | 145 |
| TOTAL from 46 OTO's from Lowline Canal: 4,780 | | | | | |
| From Highline: 2,467 | | | | | |
| PROJECT TOTAL: 7,247 | | | | | |

GENERAL CONSIDERATIONS

Landowners of the Hysham Bench area have decided to change their farm practice and land use from dry farming to irrigation farming. They have confirmed that decision by obligating themselves to repay the cost of constructing main project works, consisting of a power-transmission line, pumping stations and main canals with appurtenant structures, including turnouts from the canals.

Thus, the first step has been taken toward transforming the land economy of the area from that of hazardous, uncertain and limited, dry farming to the stable flexible economy of irrigation. The landowners did not make that decision and take this first step blindly or under promotional pressure, or under the temptation of "free" public money. They have had years of experience in dry farming and have been able to compare it with the established irrigated agriculture of the Yellowstone valley, even in their own neighborhood. No one could be better qualified than these farmers to judge the overall "economic feasibility of their undertaking.

The decision has been made and the first step has been taken. Horse racers say, "They pay at the wire, not at the post." The payoff of irrigation development is on the farm, not on main project structures, however monumental they may be. To get to this payoff each farmer must develop his irrigated agriculture, and he can not do this until water is available to his farm.

The foregoing report represents an earnest effort to assist the Treasure County Soil Conservation District in carrying its program forward by contributing a technical plan to help accomplish the second necessary step in development of irrigation on the Hysham Bench area ..

to make the water available to the farms. It is most earnestly recommended that all landowners cooperate in every way possible to assure that this necessary second step is carried out with the least possible delay. A workable distribution system, ready to function at the earliest possible time is essential to the full success of the project: And, to repeat a statement made earlier in this report, "To a great degree the success of one is dependent on the success of all."

RECOMMENDATIONS

It is recommended that the plan set forth in the foregoing report be given full and careful consideration by the Board of Supervisors of the Treasure County Soil Conservation District: That, in such consideration, they consult with landowners and prospective water users of the Hysham Bench Project. The further recommendation is made that, upon approval by the Governing Body of the District, this plan be incorporated into the conservation program and plans of the Treasure County Soil Conservation District.

It is also recommended that the Board of Directors of the Hysham Bench Water Users Association, and the members of that association, study the plan carefully and, upon their approval of it, adopt it as the "recommended plan" for the distribution and disposal of water on their project. It is most earnestly recommended that all appropriate measures be taken to the end that an adequate system for delivery of water and disposal of excess water be made available at the earliest time possible. This report and plan will be made fully available to help, as it may, to accomplish this purpose.

**To See The
Large Map(s)
Attached To
This File,
Please Contact
The Billings
Regional
Office.**